



COUNTY GOVERNMENT OF LAMU
DEPARTMENT OF WATER MANAGEMENT
AND CONSERVATION



TENDER DOCUMENT

**FOR CONSTRUCTION OF JUHUDI MARAFA, SALAMA- WIDHO PIPELINE
EXTENSION.**

TENDER NO. CGL/TND/WATER/010/2020-2021

(NEGOTIATION NUMBER: 824621-2)

RE-TENDERED

TABLE OF CONTENTS

PAGE

TABLE OF CONTENTS

PAGE

SECTION I	INVITATION FOR TENDERS	3
SECTION II	INSTRUCTIONS TO TENDERERS	4
SECTION III	CONDITIONS OF CONTRACT	13
SECTION IV	EVALUATION CRITERIA	23
SECTION V	STANDARD FORMS	25
SECTION VI	SPECIFICATIONS, DRAWINGS AND BILLS OF QUANTITIES/SCHEDULE OF RATE	46

SECTION I

INVITATION FOR TENDERS

Tender Reference No. TENDER NO. CGL/TND/WATER/010/2020-2021

**Tender Name: FOR CONSTRUCTION OF JUHUDI MARAFA, SALAMA- WIDHO
PIPELINE EXTENSION**

County government of Lamu invites sealed tenders for;

**FOR CONSTRUCTION OF JUHUDI MARAFA, SALAMA-WIDHO
PIPELINE EXTENSION.**

- 12** Interested eligible candidates may obtain further information and inspect the tender documents at Supply Chain Management office at the County Treasury located in Lamu during normal working hours or visit Lamu County Government website <http://www.lamu.go.ke>.
- 13** A complete set of tender documents shall be made available on the Lamu County Government website: <http://www.lamu.go.ke>.
- 14** Prices quoted should be net inclusive of all taxes, must be in Kenya shillings and shall remain valid for 120 days from the closing date of tender.
- 15** Completed tender documents are to be addressed to **(COUNTY GOVERNMENT OF LAMU P.O BOX 74- 80500 LAMU and should be submitted electronically through IFMIS supplier portal at www.supplier.treasury.go.ke** so as to be received on or before **Wednesday 17th March, 2021 at 11.00 a.m.**
- 16** Tenders will be opened immediately thereafter in the presence of the candidates or their representatives who choose to attend at County Government of Lamu Board Room, Mokowe.

For *(Accounting Officer/ County Government of Lamu)*

SECTION II
INSTRUCTIONS TO TENDERERS
TABLE OF CONTENTS

CLAUSE	PAGE.
1. GENERAL	4
2. TENDER DOCUMENTS	5
3. PREPARATION OF TENDERS	5
4. SUBMISSION OF TENDERS	6
5. TENDER OPENING AND EVALUATON	7
6. AWARD OF CONTRACT	8

INSTRUCTIONS TO TENDERERS.

1. General

- 1.1 The Employer as defined in the Appendix to Conditions of Contract invites tenders for Works Contract as described in the tender documents. The successful Tenderer will be expected to complete the Works by the Intended Completion Date specified in the said Appendix.
- 1.2 Tenderers shall include the following information and documents with their tenders, unless otherwise stated:
 - (a) Principal place of business;
 - (b) experience in works of a similar nature and size for each of the last 3 years, and clients who may be contacted for further information on these contracts;
 - (c) major items of construction equipment owned;
 - (d) qualifications and experience of two key technical personnel proposed for the Contract;
 - (e) Authority to seek references from the Tenderer's bankers.
 - (f) Audited Financial Accounts for the last two years;
 - (g) Certified Copy of Certificate of Incorporation/Registration.
 - (h) Certified Copy of Current Tax Compliance certificate from Kenya Revenue Authority.
 - (i) Certified Copy of Valid and current Business Permit.
 - (j) Disclosure of business ownership (Directors/ Partners /Sole Proprietor). Attach a copy of CR12 Form
- 1.3 The Tenderer shall bear all costs associated with the preparation and submission of his tender, and the Employer will in no case be responsible or liable for those costs.
- 1.4 The Tenderer, at the Tenderer's own responsibility and risk, is encouraged to visit and examine the Site of the Works and its surroundings, and obtain all information that may be necessary for preparing the tender and entering into a contract for construction of the Works. The costs of visiting the Site shall be at the Tenderer's own expense.
- 1.5 The procurement entity's employees, committee members, board members and their relative (spouse and children) are not eligible to participate in the tender.

2. Tender Documents

- 2.1 The complete set of tender documents comprises the documents listed here below and any addenda issued in accordance with clause 2.4 here below:-
 - (a) These instructions to Tenderers
 - (b) Form of Tender
 - (c) Conditions of Contract and Appendix to Conditions of Contract
 - (d) Specifications
 - (e) Drawings
 - (f) Bills of Quantities/Schedule of Rates (whichever is applicable)
 - (g) Other materials required to be filled and submitted in accordance with these Instructions and Conditions

- 2.2 The Tenderer shall examine all instructions, forms and specifications in the tender documents. Failure to furnish all information required by the tender documents may result in rejection of his tender.
- 2.3 A prospective Tenderer making inquiries of the tendering documents may notify the Employer in writing or by cable, telex or facsimile at the address indicated in the letter of invitation to tender. The Employer will respond to any request for clarification received earlier than seven [7] days prior to the deadline for submission of tenders. Copies of the Employer's response will be forwarded to all persons issued with tendering documents, including a description of the inquiry, but without identifying its source.
- 2.4 Before the deadline for submission of tenders, the Employer may modify the tendering documents by issuing addenda. Any addendum thus issued shall be part of the tendering documents and shall be communicated in writing or by cable, telex or facsimile to all Tenderers. Prospective Tenderers shall acknowledge receipt of each addendum in writing to the Employer.
- 2.5 To give prospective Tenderers reasonable time in which to take an addendum into account in preparing their tenders, the Employer shall extend, as necessary, the deadline for submission of tenders in accordance with clause 4.2 here below.

3. Preparation of Tenders

- 3.1 All documents relating to the tender and any correspondence shall be in English Language.
- 3.2 The tender submitted by the Tenderer shall comprise the following:-
 - (a) The Tender;
 - (b) Tender Security;
 - (c) Priced Bill of Quantities/Schedule of Rates for lump-sum Contracts
 - (d) Any other materials required to be completed and submitted by Tenderers.
- 3.3 The Tenderer shall fill in rates and prices for all items of the Works described in the Bill of Quantities/Schedule of Rates. Items for which no rate or price is entered by the Tenderer will not be paid for when executed and shall be deemed covered by the other rates and prices in the Bill of Quantities/Schedule of Rates. All duties, taxes and other levies payable by the Contractor under the Contract, as of 30 days prior to the deadline for submission of tenders, shall be included in the tender price submitted by the Tenderer.
- 3.4 The rates and prices quoted by the Tenderer shall not be subject to any adjustment during the performance of the Contract.
- 3.5 The unit rates and prices shall be in Kenya Shillings.
- 3.6 Tenders shall remain valid for a period of ninety (90) days from the date of submission. However in exceptional circumstances, the Employer may request that the Tenderers extend

the period of validity for a specified additional period. The request and the Tenderers' responses shall be made in writing.

- 3.7 The Tenderer shall prepare one original of the documents comprising the tender documents as described in these Instructions to Tenderers.
- 3.8 The original shall be typed or written in indelible ink and shall be signed by a person or persons duly authorized to sign on behalf of the Tenderer. All pages of the tender where alterations or additions have been made shall be initialed by the person or persons signing the tender.
- 3.9 Clarification of tenders shall be requested by the tenderer to be received by the County Government of Lamu not later than 7 days prior to the deadline for submission of tenders.
- 3.10 The County Government of Lamu shall reply to any clarifications sought by the tenderer within 3 days of receiving the request to enable the tenderer to make timely submission of its tender.

4. Submission of Tenders

- 4.1 The tender duly filled and sealed in an envelope shall;
 - (a) be addressed to the Employer at the address provided in the invitation to tender;
 - [b] bear the name and identification number of the Contract as defined in the invitation to tender; and
 - [c] provide a warning not to open before the specified time and date for tender opening.
 - (d) be submitted in both original and copy.
- 4.2 Tenders shall be delivered to the Employer at the address specified above not later than the time and date specified in the invitation to tender.
- 4.3 The tenderer shall not submit any alternative offers unless they are specifically required in the tender documents.

Only one tender may be submitted by each tenderer. Any tenderer who fails to comply with this requirement will be disqualified.
- 4.4 Any tender received after the deadline for opening tenders will be returned to the tenderer unopened.
- 4.5 The Employer may extend the deadline for submission of tenders by issuing an amendment in accordance with sub-clause 2.5 in which case all rights and obligations of the Employer and the Tenderers previously subject to the original deadline will then be subject to the new deadline.

5. Tender Opening and Evaluation

- 5.1 The tenders will be opened in the presence of the Tenderers' representatives who choose to attend at the time and in the place specified in the invitation to tender.
- 5.2 The Tenderers' names, the total amount of each tender and such other details as may be considered appropriate, will be announced at the opening by the Employer. Minutes of the tender opening, including the information disclosed to those present will also be prepared by the Employer.
- 5.3 Information relating to the examination, clarification, evaluation and comparison of tenders and recommendations for the award of the Contract shall not be disclosed to Tenderers or any other persons not officially concerned with such process until the award to the successful Tenderer has been announced. Any effort by a Tenderer to influence the Employer's officials, processing of tenders or award decisions may result in the rejection of his tender.
 - (a) There will be no correction of errors.
- 5.4 The tender evaluation committee shall evaluate the tender within 30 days of the validity period from the date of opening the tender.
- 5.5 Contract price variations shall not be allowed for contracts not exceeding one year (12 months)
- 5.6 Where contract price variation is allowed, the valuation shall not exceed 15% of the original contract price.

- 5.7 Price variation requests shall be processed by the County Government of Lamu within 30 days of receiving the request.
- 5.8 Preference where allowed in the evaluation of tenders shall not exceed 15%
- 5.9 To assist in the examination, evaluation, and comparison of tenders, the Employer at his discretion, may request [in writing] any Tenderer for clarification of the tender, including breakdowns of unit rates. The request for clarification and the response shall be in writing or by cable, telex or facsimile but no change in the tender price or substance of the tender shall be sought, offered or permitted.
- 5.10 The Tenderer shall not influence the Employer on any matter relating to his tender from the time of the tender opening to the time the Contract is awarded. Any effort by the Tenderer to influence the Employer or his employees in his decision on tender evaluation, tender comparison or Contract award may result in the rejection of the tender.

6. Award of Contract

- 6.1 The award of the Contract will be made to the Tenderer who has scored the highest combined scores.
- 6.2 Notwithstanding the provisions of clause 6.1 above, the Employer reserves the right to accept or reject any tender and to cancel the tendering process and reject all tenders at any time prior to the award of Contract without thereby incurring any liability to the affected Tenderer or Tenderers or any obligation to inform the affected Tenderer or Tenderers of the grounds for the action.
- 6.3 The Tenderer whose tender has been accepted will be notified of the award prior to expiration of the tender validity period in writing or by cable, telex or facsimile. This notification (hereinafter and in all Contract documents called the “Letter of Acceptance”) will state the sum [hereinafter and in all Contract documents called the “Contract Price” which the Employer will pay the Contractor in consideration of the execution, completion, and maintenance of the Works by the Contractor as prescribed by the Contract. The contract shall be formed on the parties signing the contract. At the same time the other tenderers shall be informed that their tenders have not been successful.
- 6.4 The Contract Agreement will incorporate all agreements between the Employer and the successful Tenderer. It will be signed by the Employer and sent to the successful Tenderer, within 30 days following the notification of award. Within 21 days of receipt, the successful Tenderer will sign the Agreement and return it to the Employer.
- 6.5 Within 21 days after receipt of the Letter of Acceptance, the successful Tenderer shall deliver to the Employer a Performance Security amount stipulated in the Appendix to Conditions of Contract.
- 6.6 The parties to the contract shall have it signed within 30 days from the date of notification of contract award unless there is an administrative review request.

- 6.7 The County Government of Lamu may at any time terminate procurement proceedings before contract award and shall not be liable to any person for the termination.
- 6.8 The County Government of Lamu shall give prompt notice of the termination to the tenderers and on request give its reasons for termination within 14 day of receiving the request from any tenderer.

7. Terms of Payment.

The County Government of Lamu shall not pay any advance payment on this works. Payments will be based on work done.

8. Corrupt and fraudulent practices

- 8.1 The County Government of Lamu requires that the tenderer observes the highest standard of ethics during the procurement process and execution of the contract. A tenderer shall sign a declaration that he has not and will not be involved in corrupt and fraudulent practices.
- 8.2 The County Government of Lamu will reject a tender if it determines that the tenderer recommended for award has engaged in corrupt and fraudulent practices in competing for the contract in question.
- 8.3 Further a tenderer who is found to have indulged in corrupt and fraudulent practices risks being debarred from participating in public procurement in Kenya.

APPENDIX TO INSTRUCTIONS TO TENDERERS

The following information regarding the particulars of the tender shall complement supplement or amend the provisions of the instructions to tenderers. Wherever there is a conflict between the provision of the instructions to tenderers and the provisions of the appendix, the provisions of the appendix herein shall prevail over those of the instructions to tenderers.

INSTRUCTIONS TO TENDERERS REFERENCE	PARTICULARS OF APPENDIX TO INSTRUCTIONS TO TENDERS
1.1	<p>This Invitation for Tenders is open to all tenderers eligible as described below:</p> <p>(a) the person has the legal capacity to enter into a contract for procurement or asset disposal;</p> <p>(b) the person is not insolvent, in receivership, bankrupt or in the process of being wound up;</p> <p>(c) the person, if a member of a regulated profession, has satisfied all the professional requirements;</p>

	<p>(d) the procuring entity is not precluded from entering into the contract with the person under section 38 of PPAD Act (MUST complete the attached form);</p> <p>(e) the person and his or her sub-contractor, if any, is not debarred from participating in procurement proceedings under Part XI of PPAD Act (MUST complete the attached form);</p> <p>(f) the person has fulfilled tax obligations;</p> <p>(g) the person has not been convicted of corrupt or fraudulent practices; and</p> <p>(h) is not guilty of any serious violation of fair employment laws and practices.</p>
1.2	<p>Tenderers are required to provide copies of the following documents:</p> <p>a) Audited Financial Accounts for the last two years.</p> <p>b) Certified Copy of Certificate of Incorporation/Registration.</p> <p>c) Certified Copy of Current Tax Compliance certificate from Kenya Revenue Authority.</p> <p>d) KRA Pin Certificate.</p> <p>e) Certified Copy of Valid and current Business Permit.</p> <p>f) Disclosure of business ownership (Directors/ Partners /Sole Proprietor). Attach a copy of CR12 Form</p>
1.3	<p>The tender security shall be 2% of the tender amount from a reputable bank or insurance companies approved by PPRA and submitted in any of the following forms:</p> <p>a) Cash</p> <p>b) A bank guarantee</p> <p>c) Such insurance guarantee approved by the Authority</p> <p>d) Letter of credit.</p>
1.5	Tenders will close on 17th March, 2021 at 11:00 a.m.
1.6	No advance payment acceptable for this tender
1.7	<p>The inquiry address is hereby given as Lamu County Government, PO BOX 74- 80500 Lamu.</p> <p>Only written inquiries are accepted</p>
1.8	<p>Documentary evidence for those submitting tenders for this works shall comprise of;</p> <p>a) Drawings</p> <p>b) Equipment Data Sheet</p> <p>c) Performance charts,</p> <p>d) CVs for site management and technical persons</p> <p>e) Work plan/schedule</p>
1.9	Tenders validity shall be 120 days from the date of Tender Opening
1.10	Tenders shall be submitted in the IFMIS Suppliers portal and should be properly marked.
1.11	Price offers as read during Tender Opening shall be evaluated as is without conducting arithmetic checks.

1.12	Post-qualification shall not be done.
1.13	Qualification criteria has been detailed further in Section VII of this Tender Document (Evaluation Criteria)

SECTION III
CONDITIONS OF CONTRACT
Table of Clauses

	Page
1. DEFINITIONS.....	11
2. CONTRACT DOCUMENTS.....	12
3. EMPLOYER’S REPRESENTATIVE’S DECISIONS.....	13
4. WORKS, LANGUAGE AND LAW OF CONTRACT.....	13
5. SAFETY, TEMPORARY WORKS AND DISCOVERIES.....	13
6. WORK PROGRAM AND SUB-CONTRACTING.....	13
7. THE SITE.....	13 - 14
8. INSTRUCTIONS.....	14
9. EXTENSION OF COMPLETION DATE.....	14 - 15
10. MANAGEMENT MEETINGS.....	15
11. DEFECTS.....	15 - 16
12. BILLS OF QUANTITIES/SCHEDULE OF RATES.....	16
13. VARIATIONS.....	16
14. PAYMENT CERTIFICATES AND FINAL ACCOUNT	16 - 17
15. INSURANCES	18
16. LIQUIDATED DAMAGES.....	18
17. COMPLETION AND TAKING OVER.....	18
18. TERMINATION.....	18 - 19
19. PAYMENT UPON TERMINATION.....	19
20. CORRUPT GIFTS AND PAYMENTS OF COMMISSION.....	19 - 20
21. SETTLEMENT OF DISPUTES.....	20
22. APPENDIX TO CONDITIONS OF CONTRACT	21 – 22

SECTION III - CONDITIONS OF CONTRACT

1. Definitions

1.1 In this Contract, except where context otherwise requires, the following terms shall be interpreted as indicated;

“Bills of Quantities” means the priced and completed Bill of Quantities forming part of the tender [where applicable].

“Schedule of Rates” means the priced Schedule of Rates forming part of the tender [where applicable].

“The Completion Date” means the date of completion of the Works as certified by the Employer’s Representative.

“The Contract” means the agreement entered into by the Employer and the Contractor as recorded in the Agreement Form and signed by the parties.

“The Contractor” refers to the person or corporate body whose tender to carry out the Works has been accepted by the Employer.

“The Contractor’s Tender” is the completed tendering document submitted by the Contractor to the Employer.

“The Contract Price” is the price stated in the Letter of Acceptance.

“Days” are calendar days; **“Months”** are calendar months.

“A Defect” is any part of the Works not completed in accordance with the Contract.

“The Defects Liability Certificate” is the certificate issued by Employer’s Representative upon correction of defects by the Contractor.

“The Defects Liability Period” is the period named in the Appendix to Conditions of Contract and calculated from the Completion Date.

“Drawings” include calculations and other information provided or approved by the Employer’s Representative for the execution of the Contract.

“Employer” Includes Central or Local Government administration, Universities, Public Institutions and Corporations and is the party who employs the Contractor to carry out the Works.

“Equipment” is the Contractor’s machinery and vehicles brought temporarily to the Site for the execution of the Works.

“Site” means the place or places where the permanent Works are to be carried out including workshops where the same is being prepared.

“Materials” are all supplies, including consumables, used by the Contractor for incorporation in the Works.

“Employer’s Representative” is the person appointed by the Employer and notified to the Contractor for the purpose of supervision of the Works.

“Specification” means the Specification of the Works included in the Contract.

“Start Date” is the date when the Contractor shall commence execution of the Works.

“ A Subcontractor” is a person or corporate body who has a Contract with the Contractor to carry out a part of the Work in the Contract, which includes Work on the Site.

“Temporary works” are works designed, constructed, installed, and removed by the Contractor which are needed for construction or installation of the Works.

“ A Variation” is an instruction given by the Employer’s Representative which varies the Works.

“The Works” are what the Contract requires the Contractor to construct, install, and turnover to the Employer.

2. Contract Documents

2.1 The following documents shall constitute the Contract documents and shall be interpreted in the following order of priority;

- (1) Agreement,
- (2) Letter of Acceptance,
- (3) Contractor’s Tender,
- (4) Conditions of Contract,
- (5) Specifications,
- (6) Drawings,
- (7) Bills of Quantities or Schedule of Rates [whichever is applicable)

3. Employer’s Representative’s Decisions

3.1 Except where otherwise specifically stated, the Employer’s Representative will decide contractual matters between the Employer and the Contractor in the role representing the Employer.

4. Works, Language and Law of Contract

4.1 The Contractor shall construct and install the Works in accordance with the Contract documents. The Works may commence on the Start Date and shall be carried out in accordance with the Program submitted by the Contractor, as updated with the approval of the Employer’s Representative, and complete them by the Intended Completion Date.

4.2 The ruling language of the Contract shall be English language and the law governing the Contract shall be the law of the Republic of Kenya.

5. Safety, Temporary works and Discoveries

5.1 The Contractor shall be responsible for design of temporary works and shall obtain approval of third parties to the design of the temporary works where required.

5.2 The Contractor shall be responsible for the safety of all activities on the Site.

5.3 Any thing of historical or other interest or significant value unexpectedly discovered on the Site shall be the property of the Employer. The Contractor shall notify the Employer's Representative of such discoveries and carry out the Employer's

5.4 Representative's instructions for dealing with them.

6 Work Program and Sub-contracting

6.1 Within seven days after Site possession date, the Contractor shall submit to the Employer's Representative for approval a program showing the general methods, arrangements, order and timing for all the activities in the Works.

6.2 The Contractor may sub-contract the Works (but only to a maximum of 25 percent of the Contract Price) with the approval of the Employer's Representative. However, he shall not assign the Contract without the approval of the Employer in writing. Sub-contracting shall not alter the Contractor's obligations.

7 The site

7.1 The Employer shall give possession of all parts of the Site to the Contractor.

7.2 The Contractor shall allow the Employer's Representative and any other person authorised by the Employer's Representative, access to the Site and to any place where work in connection with the Contract is being carried out or is intended to be carried out.

8 Instructions

8.1 The Contractor shall carry out all instructions of the Employer's Representative which are in accordance with the Contract.

9 Extension of Completion Date

9.1 The Employer's Representative shall extend the Completion Date if an occurrence arises which makes it impossible for completion to be achieved by the Intended Completion Date. The

Employer's Representative shall decide whether and by how much to extend the Completion Date.

9.2 For the purposes of this clause, the following occurrences shall be valid for consideration;

Delay by:-

- (a) force majeure, or
- (b) reason of any exceptionally adverse weather conditions, or
- (c) reason of civil commotion, strike or lockout affecting any of the trades employed upon the Works or any of the trades engaged in the preparation, manufacture or transportation of any of the goods or materials required for the Works, or
- (d) reason of the Employer's Representative's instructions issued under these Conditions, or
- (e) reason of the contractor not having received in due time necessary instructions, drawings, details or levels from the Employer's Representative for which he specifically applied in writing on a date which having regard to the date for Completion stated in the appendix to these Conditions or to any extension of time then fixed under this clause was neither unreasonably distant from nor unreasonably close to the date on which it was necessary for him to receive the same, or
- (f) delay on the part of artists, tradesmen or others engaged by the Employer in executing work not forming part of this Contract, or
- (g) reason of delay by statutory or other services providers or similar bodies engaged directly by the Employer, or
- (h) reason of opening up for inspection of any Work covered up or of the testing or any of the Work, materials or goods in accordance with these conditions unless the inspection or test showed that the Work, materials or goods were not in accordance with this Contract, or
- (i) reason of delay in appointing a replacement Employer's Representative, or
- (j) reason of delay caused by the late supply of goods or materials or in executing Work for which the Employer or his agents are contractually obliged to supply or to execute as the case may be, or
- (k) delay in receiving possession of or access to the Site.

10 Management Meetings

10.1 A Contract management meeting shall be held regularly and attended by the Employer's Representative and the Contractor. Its business shall be to review the plans for the remaining Work. The Employer's Representative shall record the business of management meetings and provide copies of the record to those attending the meeting and the Employer. The responsibility of the parties for

actions to be taken shall be decided by the Employer's Representative either at the management meeting or after the management meeting and stated in writing to all who attend the meeting.

10.2 Communication between parties shall be effective only when in writing.

11 Defects

11.1 The Employer's Representative shall inspect the Contractor's work and notify the Contractor of any defects that are found. Such inspection shall not affect the Contractor's responsibilities. The Employer's Representative may instruct the Contractor to search for a defect and to uncover and test any Work that the Employer's Representative considers may have a defect. Should the defect be found, the cost of uncovering and making good shall be borne by the Contractor. However if there is no defect found, the cost of uncovering and making good shall be treated as a variation and added to the Contract Price.

11.2 The Employer's Representative shall give notice to the Contractor of any defects before the end of the Defects Liability Period, which begins at Completion, and is defined in the Appendix to Conditions of Contract.

11.3 Every time notice of a defect is given, the Contractor shall correct the notified defect within the length of time specified by the Employer's Representative's notice. If the Contractor has not corrected a defect within the time specified in the Employer's Representative's notice, the Employer's Representative will assess the cost of having the defect corrected by other parties and such cost shall be treated as a variation and be deducted from the Contract Price.

12 Bills of Quantities/Schedule of Rates

12.1 The Bills of Quantities/Schedule of Rates shall contain items for the construction, installation, testing and commissioning of the Work to be done by the Contractor. The Contractor will be paid for the quantity of the Work done at the rates in the Bills of Quantities/Schedule of Rates for each item. Items against which no rate is entered by the Tenderer will not be paid for when executed and shall be deemed covered by the rates for other items in the Bills of Quantities/Schedule of Rates.

12.2 Where Bills of Quantities do not form part of the Contract, the Contract Price shall be a lump sum (which shall be deemed to have been based on the rates in the Schedule of Rates forming part of the tender) and shall be subject to re-measurement after each stage.

13 Variations

13.1 The Contractor shall provide the Employer's Representative with a quotation for carrying out the variations when requested to do so. The Employer's Representative shall assess the quotation and shall obtain the necessary authority from the Employer before the variation is ordered.

13.2 If the Work in the variation corresponds with an item description in the Bill of Quantities/Schedule of Rates, the rate in the Bill of Quantities/Schedule of Rates shall be used to calculate the value of the variation. If the nature of the Work in the variation does not correspond with items in the Bill of Quantities/Schedule of Rates, the quotation by the Contractor shall be in the form of new rates for the relevant items of Work.

- 13.3 If the Contractor's quotation is unreasonable, the Employer's Representative may order the variation and make a change to the Contract Price, which shall be based on the Employer's Representative's own forecast of the effects of the variation on the Contractor's costs.

14 Payment Certificates and Final Account

- 14.1 The Contractor shall be paid after each of the following stages of Work listed herebelow (subject to re-measurement by the Employer's Representative of the Work done in each stage before payment is made). In case of lump-sum Contracts, the valuation for each stage shall be based on the quantities so obtained in the re-measurement and the rates in the Schedule of Rates.

- (i) Advance payment _____ (percent of Contract Price, [after Contract execution] to be inserted by the Employer).
- (ii) First stage (*define stage*) _____
- (iii) Second stage (*define stage*) _____
- (iv) Third stage (*define stage*) _____
- (v) After defects liability period.

- 14.2 Upon deciding that Works included in a particular stage are complete, the Contractor shall submit to the Employer's Representative his application for payment. The Employer's Representative shall check, adjust if necessary and certify the amount to be paid to the Contractor within 21 days of receipt of the Contractor's application. The Employer shall pay the Contractor the amounts so certified within 30 days of the date of issue of each Interim Certificate.

- 14.3 The Contractor shall supply the Employer's Representative with a detailed final account of the total amount that the Contractor considers payable under the Contract before the end of the Defects Liability Period. The Employer's Representative shall issue a Defect Liability Certificate and certify any final payment that is due to the Contractor within 30 days of receiving the Contractor's account if it is correct and complete. If it is not, the Employer's Representative shall issue within 21 days a schedule that states the scope of the corrections or additions that are necessary. If the final account is still unsatisfactory after it has been resubmitted, the Employer's Representative shall decide on the amount payable to the Contractor and issue a Final Payment Certificate. The Employer shall pay the Contractor the amount so certified within 60 days of the issue of the Final Payment Certificate.

- 14.4 If the period laid down for payment to the Contractor upon each of the Employer's Representative's Certificate by the Employer has been exceeded, the Contractor shall be entitled to claim simple interest calculated pro-rata on the basis of the number of days delayed at the

Central Bank of Kenya's average base lending rate prevailing on the first day the payment becomes overdue. The Contractor will be required to notify the Employer within 15 days of receipt of delayed payments of his intentions to claim interest.

15. Insurance

- 15.1 The Contractor shall be responsible for and shall take out appropriate cover against, among other risks, personal injury; loss of or damage to the Works, materials and plant; and loss of or damage to property.

16. Liquidated Damages

- 16.1 The Contractor shall pay liquidated damages to the Employer at the rate 0.001 per cent of the Contract price per day for each day that the actual Completion Date is later than the Intended Completion Date except in the case of any of the occurrences listed under clause 9.2. The Employer may deduct liquidated damages from payments due to the Contractor. Payment of liquidated damages shall not affect the Contractor's liabilities.

17. Completion and Taking Over

- 17.1 Upon deciding that the Work is complete the Contractor shall request the Employer's Representative to issue a Certificate of Completion of the Works, upon deciding that the Work is completed.

The Employer shall take over the Site and the Works within seven days of the Employer's Representative issuing a Certificate of Completion.

18. Termination

- 18.1 The Employer or the Contractor may terminate the Contract if the other party causes a fundamental breach of the Contract. These fundamental breaches of Contract shall include, but shall not be limited to, the following;

- (a) the Contractor stops Work for 30 days continuously without reasonable cause or authority from the Employer's Representative;
- (b) the Contractor is declared bankrupt or goes into liquidation other than for a reconstruction or amalgamation;
- (c) a payment certified by the Employer's Representative is not paid by the Employer to the Contractor within 30 days after the expiry of the payment periods stated in sub clauses 14.2 and 14.3 hereinabove.
- (d) the Employer's Representative gives notice that failure to correct a particular defect is a fundamental breach of Contract and the Contractor fails to correct it within a reasonable period of time.

- 18.2 If the Contract is terminated, the Contractor shall stop Work immediately, and leave the Site as soon as reasonably possible. The Employer's Representative shall immediately thereafter arrange for a meeting for the purpose of taking record of the Works executed and materials, goods, equipment and temporary buildings on Site.

19. Payment Upon Termination

- 19.1 The Employer may employ and pay other persons to carry out and complete the Works and to rectify any defects and may enter upon the Works and use all materials on Site, plant, equipment and temporary works.
- 19.2 The Contractor shall, during the execution or after the completion of the Works under this clause, remove from the Site as and when required within such reasonable time as the Employer's Representative may in writing specify, any temporary buildings, plant, machinery, appliances, goods or materials belonging to him, and in default thereof, the Employer may (without being responsible for any loss or damage) remove and sell any such property of the Contractor, holding the proceeds less all costs incurred to the credit of the Contractor.
- 19.3 Until after completion of the Works under this clause, the Employer shall not be bound by any other provision of this Contract to make any payment to the Contractor, but upon such completion as aforesaid and the verification within a reasonable time of the accounts therefor the Employer's Representative shall certify the amount of expenses properly incurred by the Employer and, if such amount added to the money paid to the Contractor before such determination exceeds the total amount which would have been payable on due completion in accordance with this Contract, the difference shall be a debt payable to the Employer by the Contractor; and if the said amount added to the said money be less than the said total amount, the difference shall be a debt payable by the Employer to the Contractor.

20. Corrupt Gifts and Payments of Commission

- 20.1 The Contractor shall not;
- (a) Offer or give or agree to give to any person in the service of the Employer any gifts or consideration of any kind as an inducement or reward for doing or forbearing to do or for having done or forborne to do any act in relation to the obtaining or execution of this or any other contract with the Employer or for showing or forbearing to show favour or disfavour to any person in relation to this or any other contract with the Employer.
 - (b) Any breach of this Condition by the Contractor or by anyone employed by him or acting on his behalf (whether with or without the knowledge of the Contractor) shall be an offence under the Laws of Kenya.

21. Settlement of Disputes

- 21.1 Any dispute arising out of the Contract which cannot be amicably settled between the parties shall be referred by either party to the arbitration and final decision of a person to be agreed between the parties. Failing agreement to concur in the appointment of an Arbitrator, the Arbitrator shall be appointed by the chairman of the Chartered Institute of Arbitrators, Kenya branch, on the request of the applying party.

SECTION IV**Evaluation criteria**

	MADATORY REQUIREMENTS	POINTS
1.	<p>Particulars of the Tendering Company.</p> <p>a) Certified copies of statutory documents as follows: -</p> <ul style="list-style-type: none"> • Certificate of incorporation/registration. • Current Tax Compliance certificate. • KRA Pin Certificate. • Valid NCA certificate category 7 and Above for Water works. • Valid and current trade/ Business license. • Serialized Tender Document and attached documents. • Completed confidential business questionnaire and declaration form duly filled, signed and stamped. • Disclosure of business ownership (Directors/ Partners /Sole Proprietor). Attach a copy Business CR 12 Form. • Bidder to provide self-declaration that the person/tenderer is not debarred in the matter of the public procurement and asset disposal act 2015(As per section 62 of PPDA 2015). • Bidder to provide self-declaration that the person/tenderer will not engage in any corrupt or fraudulent practice. • Form of tender duly filled, signed and stamped. • Provide Tender security which shall be 2% of the tender amount from a reputable bank or insurance companies approved by PPRA and shall be valid for 120 days from the closing date of the tender. 	Mandatory
	TECHNICAL/GENERAL REQUIREMENTS	
2	<p>Provide Details of;</p> <p>a) Company Profile (State whether joint or not). (5 marks)</p> <p>b) Contact person(s). (2 marks)</p> <p>c) Physical Address/Location. (3 marks)</p>	10
3	<p>Evidence of adequacy of working capital for this Contract</p> <p>a) Access to line(s) of credit. (3 marks)</p> <p>b) Indicate appointed bankers showing the name, address, contact person and address of bidder's bankers. (2 marks)</p> <p>c) Letter of authority from the bidder authorizing the County Government of Lamu to seek reference from the bidder's bankers. (3 marks)</p> <p>d) Bank statements for the last twelve months. (2 marks)</p>	10
4	<p>Details of experience and past performance on at least one (1) project of a similar nature within the last 3 years (2017-2020), details to include current contractors, names of clients/firms, clear physical address and contact persons. (Attach award letters, Local Purchase/ Service Orders, Signed contracts or completion certificates as</p>	20

	evidence/proof of contract) <ul style="list-style-type: none"> - <i>Name of the project of similar nature – (@ 5 point * 1 = 5 Points)</i> - <i>Address of Project – (@ 3 point *1 = 3 Points)</i> - <i>Contact persons – (@ 1 point * 1 = 1 Point)</i> - <i>The Project Value- (@ 1 Points * 1= 1 Point)</i> - <i>Proof of Such Contracts (Attach award letters/LPOs /LSOs/Signed Contracts and completion certificate. (10 Points)</i> 	
5	Documentary evidence for those submitting tenders for this works shall comprise of; <ul style="list-style-type: none"> a) Performance charts, (2 marks) b) Work plan/schedule (2 marks) c) List of equipment and state if the equipment is owned or leased and attach supporting evidence. (5 marks). 	9
6	Bidder to provide a preliminary description of the proposed work; i.e. <ul style="list-style-type: none"> a) Method and schedule (2 marks). b) The drawings (2 marks). c) The charts, as necessary (2 marks). 	6
7	Qualifications and experience of two key site management and technical personnel proposed to undertake this work. <i>Attach the CVs and Certificates of qualifications for the key staff</i> (10 marks)	10
8	Information regarding any litigation, current or during the last five years, in which the tenderer is involved, the parties concerned and disputed amount if any. (5 marks)	5
9	Attach Audited Accounts for the last two years. (2018-2020) (10marks)	10
	TOTAL	80

All information provided may be subject to confirmation by COUNTY GOVERNMENT OF LAMU providing false information will lead to disqualification. **NOTE:** Only tenders that score 60% out of 80% on technical evaluation will qualify to have their proposals for financials evaluated. Those scoring below 60% will be disqualified at this stage. Award will be given to the highest combined scorer.

Financial Evaluation

The financial evaluation shall comprise 20% of the total marks

The formulae for determining the financial score (SF) shall be as follows;

$$SF = 20 FM/F$$

Where: SF is the financial score

FM is the lowest fees quoted and

F is the fees of the quotation under consideration.

The lowest fees quoted will be allocated the maximum score of 20%. The bidder with the combined highest technical and financial score shall be awarded the tender.

SECTION V
STANDARD FORMS

List of Standard Forms

- (i) Form of Invitation for Tenders**
- (ii) Form of Tender**
- (iii) Letter of Acceptance**
- (iv) Form of Agreement**
- (v) Form of Tender Security**
- (vi) Performance Bank Guarantee**
- (vii) Performance Bond**
- (viii) Bank Guarantee for Advance Payment**
- (ix) Qualification Information**
- (x) Tender Questionnaire**
- (xi) Confidential Business Questionnaire**
- (xi) Details of Sub-Contractors**
- (xiii) Request for Review Form**

FORM OF INVITATION FOR TENDERS

_____ [date]

To: _____ [name of Contractor]
_____ [address]

Dear Sirs:

Reference: _____ [Contract Name]

You have been prequalified to tender for the above project.

We hereby invite you and other prequalified tenderers to submit a tender for the execution and completion of the above Contract.

A complete set of tender documents may be purchased by you from _____

_____ [mailing address, cable/telex/facsimile numbers].

Upon payment of a non-refundable fee of Kshs _____

All tenders must be accompanied by _____ number of copies of the same and a tender security in the form and amount specified in the tendering documents, and must be delivered to

_____ [address and location]

at or before _____ (time and date). Tenders will be opened immediately thereafter, in the presence of tenderers' representatives who choose to attend.

Please confirm receipt of this letter immediately in writing by cable/facsimile or telex.

Yours faithfully,

_____ Authorized Signature

_____ Name and Title

FORM OF TENDER

TO: _____ [Name of Employer] _____ [Date]
_____ [Name of Contract]

Dear Sir,

- In accordance with the Conditions of Contract, Specifications, Drawings and Bills of Quantities/Schedule of Rates for the execution of the above named Works, we, the undersigned offer to construct, install and complete such Works and remedy any defects therein for the sum of Kshs. [Amount in figures] Kenya Shillings _____
_____ [Amount in words]
- We undertake, if our tender is accepted, to commence the Works as soon as is reasonably possible after the receipt of the Employer’s Representative’s notice to commence, and to complete the whole of the Works comprised in the Contract within the time stated in the Appendix to Conditions of Contract.
- We agree to abide by this tender until _____ [Insert date], and it shall remain binding upon us and may be accepted at any time before that date.
- Unless and until a formal Agreement is prepared and executed this tender together with your written acceptance thereof, shall constitute a binding Contract between us.
- We understand that you are not bound to accept the lowest or any tender you may receive.

Dated this _____ day of _____ 20 _____

Signature _____ in the capacity of _____

duly authorized to sign tenders for and on behalf of
_____ [Name of Tenderer] of
_____ [Address of Tenderer]

Witness; Name _____

Address _____

Signature and Stamp _____

Date _____

(Amend accordingly if provided by Insurance Company)

LETTER OF ACCEPTANCE
[Letterhead paper of the Employer]

_____ [date]

To: _____
[name of the Contractor]

[address of the Contractor]

Dear Sir,

This is to notify you that your Tender dated _____
for the execution of _____
[name of the Contract and identification number, as given in the Tender documents] for the Contract Price of
Kshs. _____ [amount in figures] [Kenya
Shillings _____ (amount in words)] in accordance with the Instructions to
Tenderers is hereby accepted.

You are hereby instructed to proceed with the execution of the said Works in accordance with the Contract documents.

Authorized Signature

Name and Title of Signatory

Attachment : Agreement

FORM OF AGREEMENT

THIS AGREEMENT, made the _____ day of _____ 20 _____

between _____ of [or whose registered office is situated at] _____ (hereinafter called “the Employer”) of the one part AND _____ of [or whose registered office is situated at] _____ (hereinafter called “the Contractor”) of the other part.

WHEREAS THE Employer is desirous that the Contractor executes

_____ (*name and identification number of Contract*) (hereinafter called “the Works”) located at _____ [*Place/location of the Works*] and the Employer has accepted the tender submitted by the Contractor for the execution and completion of such Works and the remedying of any defects therein for the Contract Price of Kshs _____ [*Amount in figures*], Kenya Shillings _____ [*Amount in words*].

NOW THIS AGREEMENT WITNESSETH as follows:0

1. In this Agreement, words and expressions shall have the same meanings as are respectively assigned to them in the Conditions of Contract hereinafter referred to.
2. The following documents shall be deemed to form and shall be read and construed as part of this Agreement i.e.
 - (i) Letter of Acceptance
 - (ii) Form of Tender
 - (iii) Conditions of Contract Part I
 - (iv) Conditions of Contract Part II and Appendix to Conditions of Contract
 - (v) Specifications
 - (vi) Drawings
 - (vii) Priced Bills of Quantities/Priced Schedule of Rates [whichever is applicable]

3. In consideration of the payments to be made by the Employer to the Contractor as hereinafter mentioned, the Contractor hereby covenants with the Employer to execute and complete the Works and remedy any defects therein in conformity in all respects with the provisions of the Contract.

4. The Employer hereby covenants to pay the Contractor in consideration of the execution and completion of the Works and the remedying of defects therein, the Contract Price or such other sum as may become payable under the provisions of the Contract at the times and in the manner prescribed by the Contract.

IN WITNESS whereof the parties thereto have caused this Agreement to be executed the day and year first before written.

The common Seal of _____

Was hereunto affixed in the presence of _____

Signed Sealed, and Delivered by the said _____

Binding Signature of Employer _____

Binding Signature of Contractor _____

In the presence of (i) Name _____

Address _____

Signature _____

[ii] Name _____

Address _____

Signature _____

FORM OF TENDER SECURITY

WHEREAS(hereinafter called “the Tenderer”) has submitted his tender dated for the construction of
..... (name of Contract)

KNOW ALL PEOPLE by these presents that WE having our registered office at(hereinafter called “the Bank”), are bound unto(hereinafter called “the Employer”) in the sum of Kshs.....for which payment well and truly to be made to the said Employer, the Bank binds itself, its successors and assigns by these presents sealed with the Common Seal of the said Bank this Day of20.....

THE CONDITIONS of this obligation are:

If after tender opening the tenderer withdraws his tender during the period of tender validity specified in the instructions to tenderers
Or

If the tenderer, having been notified of the acceptance of his tender by the Employer during the period of tender validity:

- (a) fails or refuses to execute the form of Agreement in accordance with the Instructions to Tenderers, if required; or
- (b) fails or refuses to furnish the Performance Security, in accordance with the Instructions to Tenderers;

We undertake to pay to the Employer up to the above amount upon receipt of his first written demand, without the Employer having to substantiate his demand, provided that in his demand the Employer will note that the amount claimed by him is due to him, owing to the occurrence of one or both of the two conditions, specifying the occurred condition or conditions.

This guarantee will remain in force up to and including thirty (30) days after the period of tender validity, and any demand in respect thereof should reach the Bank not later than the said date.

[Date]

[signature of the Bank]

[Witness]

[Seal]

PERFORMANCE BANK GUARANTEE

To: _____ (Name of Employer) _____ (Date)
_____ (Address of Employer)

Dear Sir,

WHEREAS _____ (hereinafter called “the Contractor”) has undertaken, in pursuance of Contract No. _____ dated _____ to execute _____ (hereinafter called “the Works”);

AND WHEREAS it has been stipulated by you in the said Contract that the Contractor shall furnish you with a Bank Guarantee by a recognized bank for the sum specified therein as security for compliance with his obligations in accordance with the Contract;

AND WHEREAS we have agreed to give the Contractor such a Bank Guarantee:

NOW THEREFORE we hereby affirm that we are the Guarantor and responsible to you, on behalf of the Contractor, up to a total of Kshs. _____ (amount of Guarantee in figures) Kenya Shillings _____ (amount of Guarantee in words), and we undertake to pay you, upon your first written demand and without civil or argument, any sum or sums within the limits of Kenya Shillings _____ (amount of Guarantee in words) as aforesaid without your needing to prove or to show grounds or reasons for your demand for the sum specified therein.

We hereby waive the necessity of your demanding the said debt from the Contractor before presenting us with the demand.

We further agree that no change, addition or other modification of the terms of the Contract or of the Works to be performed thereunder or of any of the Contract documents which may be made between you and the Contractor shall in any way release us from any liability under this Guarantee, and we hereby waive notice of any change, addition, or modification.

This guarantee shall be valid until the date of issue of the Certificate of Completion.

SIGNATURE AND SEAL OF THE GUARANTOR

Name of Bank _____

Address _____

Date _____

(Amend accordingly if provided by Insurance Company)

PERFORMANCE BOND

By this Bond, We _____ of (or whose registered office is situated at] _____
as Principal (hereinafter called “the Contractor”) and _____
_____ of [or whose registered office is situated at]

_____ as Surety (hereinafter called “the Surety”), are held and firmly bound unto _____ of [or whose
registered office is situated at] _____
as Obligee (hereinafter called “the Employer”) in the amount of Kshs. _____
_____ [amount of Bond in figures] Kenya Shillings

_____ [amount of Bond in words], for the payment of which sum well and truly, the Contractor and the Surety bind themselves, their heirs, executors, administrators, successors and assigns, jointly and severally, firmly by these presents.

WHEREAS the Contractor has entered into a Contract with the Employer dated the _____ day of _____ 20 _____ for the execution of

_____ [name of Contract] in accordance with the Contract documents, Specifications and amendments thereto, which to the extent herein provided for, are by reference made part hereof and are hereinafter referred to as the Contract.

NOW THEREFORE, the Condition of this Obligation is such that, if the Contractor shall promptly and faithfully perform the said Contract (including any amendments thereto), then this obligation shall be null and void; otherwise it shall remain in full force and effect. Whenever the Contractor shall be, and declared by the Employer to be, in default under the Contract, the Employer having performed the Employer’s obligations thereunder, the Surety may promptly remedy the default, or shall promptly:

- (1) complete the Contract in accordance with its terms and conditions; or

- (2) obtain a tender or tenders from qualified tenderers for submission to the Employer for completing the Contract in accordance with its terms and conditions, and upon determination by the Employer and the Surety of the lowest responsive tenderer, arrange for a Contract between such tenderer and Employer and make available as work progresses (even though there should be a default or a succession of defaults under the Contract or Contracts of completion arranged under this paragraph) sufficient funds to pay the cost of completion less the balance of the Contract Price; but not exceeding, including other costs and damages for which the Surety may be liable hereunder, the amount set forth in the first paragraph hereof.

The term "Balance of the Contract Price", as used in this paragraph, shall mean the total amount payable by the Employer to the Contractor under the

Contract, less the amount properly paid by the Employer to the Contractor; or

- (3) pay the Employer the amount required by the Employer to complete the Contract in accordance with its terms and conditions up to a total not exceeding the amount of this Bond.

The Surety shall not be liable for a greater sum than the specified penalty of this Bond.

Any suit under this Bond must be instituted before the expiration of one year from the date of issuance of the Certificate of Completion.

No right of action shall accrue on this Bond to or for the use of any person or corporation other than the Employer named herein or the heirs, executors, administrators, successors and assigns of the Employer.

In testimony whereof, the Contractor has hereunto set his hand and affixed his seal, and the Surety has caused these presents to be sealed with his corporate seal duly attested by the signature of his legal representative, this _____ day of _____ 20_____

SIGNED ON _____ SIGNED ON _____

On behalf of _____ On behalf of _____
[name of Contractor] [name of Surety]

By _____ By _____

In the capacity of _____ In the capacity of _____

In the presence of; Name _____ In the presence of; Name _____

Address _____

Address _____

Signature _____

Signature _____

Date _____

Date _____

BANK GUARANTEE FOR ADVANCE PAYMENT

To: _____ *[name of Employer]* _____ *(Date)*
_____ *[address of Employer]*

Gentlemen,

Ref: _____ *[name of Contract]*

In accordance with the provisions of the Conditions of Contract of the above-mentioned Contract, We, _____ *[name and Address of Contractor]* (hereinafter called “the Contractor”) shall deposit with _____ *[name of Employer]* a bank guarantee to guarantee his proper and faithful performance under the said Contract in an amount of Kshs. _____ *[amount of Guarantee in figures]* Kenya Shillings _____ *[amount of Guarantee in words]*.

We, _____ *[bank or financial institution]*, as instructed by the Contractor, agree unconditionally and irrevocably to guarantee as primary obligator and not as Surety merely, the payment to _____ *[name of Employer]* on his first demand without whatsoever right of objection on our part and without his first claim to the Contractor, in the amount not exceeding Kshs _____ *[amount of Guarantee in figures]* Kenya Shillings _____ *[amount of Guarantee in words]*, such amount to be reduced periodically by the amounts recovered by you from the proceeds of the Contract.

We further agree that no change or addition to or other modification of the terms of the Contract or of the Works to be performed thereunder or of any of the Contract documents which may be made between _____ [*name of Employer*] and the Contractor, shall in any way release us from any liability under this guarantee, and we hereby waive notice of any such change, addition or modification.

No drawing may be made by you under this guarantee until we have received notice in writing from you that an advance payment of the amount listed above has been paid to the Contractor pursuant to the Contract.

This guarantee shall remain valid and in full effect from the date of the advance payment under the Contract until _____ (*name of Employer*) receives full payment of the same amount from the Contract.

Yours faithfully,

Signature and Seal _____

Name of the Bank or financial institution _____

Address _____

Date _____

Witness: Name: _____

Address: _____

Signature: _____

Date: _____

QUALIFICATION INFORMATION

1. Individual Tenderers or Individual Members of Joint Ventures

1.1 Constitution or legal status of tenderer (attach copy or Incorporation Certificate);

Place of registration: _____

Principal place of business _____

Power of attorney of signatory of tender _____

1.2 Total annual volume of construction work performed in the last five years

Year	Volume	
	Currency	Value

1.3 Work performed as Main Contractor on works of a similar nature and volume over the last five years. Also list details of work under way or committed, including expected completion date.

Project name	Name of client and contact person	Type of work performed and year of completion	Value of work performed and Contract
_____	_____	_____	_____
_____	_____	_____	_____
_____	_____	_____	_____

1.4 Major items of Contractor's Equipment proposed for carrying out the Works. List all information requested below.

Item of Equipment	Description, Make and age (years)	Condition (new, good, poor) and number available	Owned, leased (from whom?), or to be purchased (from whom?)
_____	_____	_____	_____
_____ (etc .)	_____	_____	_____

1.5 Qualifications and experience of key personnel proposed for administration and execution of the Contract. Attach biographical data.

Position	Name	Years of experience (general)	Years of experience in proposed position
Project Manager	_____	_____	_____

(etc.)			

1.6 Financial reports for the last five years: balance sheets, profit and loss statements, auditor's reports, etc. List below and attach copies.

1.7 Evidence of access to financial resources to meet the qualification requirements: cash in hand, lines of credit, etc. List below and attach copies of supportive documents.

1.8 Name, address and telephone, telex and facsimile numbers of banks that may provide reference if contacted by the Employer.

1.9 Statement of compliance with the requirements of Clause 1.2 of the Instructions to Tenderers.

1.10 Proposed program (work method and schedule) for the whole of the Works.

2 Joint Ventures

2.0 The information listed in 1.1 – 2.0 above shall be provided for each partner of the joint venture.

2.1 The information required in 1.11 above shall be provided for the joint venture.

2.2 Attach the power of attorney of the signatory(ies) of the tender authorizing signature of the tender on behalf of the joint venture

2.3 Attach the Agreement among all partners of the joint venture (and which is legally binding on all partners), which shows that:

- a) all partners shall be jointly and severally liable for the execution of the Contract in accordance with the Contract terms;
- b) one of the partners will be nominated as being in charge, authorized to incur liabilities and receive instructions for and on behalf of any and all partners of the joint venture; and
- c) the execution of the entire Contract, including payment, shall be done exclusively with the partner in charge.

TENDER QUESTIONNAIRE

Please fill in block letters.

1. Full names of tenderer;
.....
2. Full address of tenderer to which tender correspondence is to be sent (unless an agent has been appointed below);
.....
3. Telephone number (s) of tenderer;
.....
4. Telex of tenderer;
.....
5. Name of tenderer's representative to be contacted on matters of the tender during the tender period;
.....
6. Details of tenderer's nominated agent (if any) to receive tender notices. This is essential if the tenderer does not have his registered address in Kenya (name, address, telephone, telex);
.....
.....

Signature of Tenderer

Make copy and deliver to: _____ (Name of Employer)

CONFIDENTIAL BUSINESS QUESTIONNAIRE

You are requested to give the particulars indicated in Part 1 and either Part 2 (a), 2 (b) or whichever applies to your type of business.

You are advised that it is a serious offence to give false information on this Form.

Part 1 – General

Business Name

Location of business premises; Country/Town.....

Plot No..... Street/Road

Postal Address..... Tel No.....

Nature of Business.....

Current Trade Licence No..... Expiring date.....

Maximum value of business which you can handle at any time: K.
pound.....

Name of your bankers.....

Branch.....

Part 2 (a) – Sole Proprietor

Your name in full..... Age.....

Nationality..... Country of Origin.....

Citizenship details

Part 2 (b) – Partnership

Give details of partners as follows:

	<i>Name in full</i>	<i>Nationality</i>	<i>Citizenship Details</i>	<i>Shares</i>
1
2
3

Name.....Date.....Sign/Company Seal.....

DETAILS OF SUB-CONTRACTORS

If the Tenderer wishes to sublet any portions of the Works under any heading, he must give below details of the sub-contractors he intends to employ for each portion.

Failure to comply with this requirement may invalidate the tender.

(1) Portion of Works to be sublet:

[i] Full name of Sub-contractor and address of head office:

.....

(ii) Sub-contractor's experience of similar works carried out in the last 3 years with Contract value:

.....

.....

(2) Portion of Works to be sublet:

(i) Full name of sub-contractor and address of head office:

.....

.....

(ii) Sub-contractor's experience of similar works carried out in the last 3 years with contract value:

.....

[Signature of Tenderer]

Date

LETTER OF NOTIFICATION OF AWARD

Employers address

To: _____

RE: Tender No. _____

Tender Name _____

This is to notify that the contract/s stated below under the above mentioned tender have been awarded to you.

1. Please acknowledge receipt of this letter of notification signifying your acceptance.
2. The contract/contracts shall be signed by the parties within 30 days of the date of this letter but not earlier than 14 days from the date of the letter.
3. You may contact the officer(s) whose particulars appear below on the subject matter of this letter of notification of award.

(*FULL PARTICULARS*) _____

SIGNED FOR ACCOUNTING OFFICER

REPUBLIC OF KENYA
PUBLIC PROCUREMENT ADMINISTRATIVE REVIEW BOARD

APPLICATION NO.....OF.....20.....

BETWEEN

.....APPLICANT

AND

.....RESPONDENT (*County Government of Lamu*)

Request for review of the decision of the..... (*Name of the employer*) of..... dated the...day of20.....in the matter of Tender No.....of.....20...

REQUEST FOR REVIEW

I/We.....,the above named Applicant(s), of address: Physical address Fax No.....Tel. No.....Email, hereby request the Public Procurement Administrative Review Board to review the whole/part of the above mentioned decision on the following grounds , namely:-

- 1.
- 2.
- etc.

By this memorandum, the Applicant requests the Board for an order/orders that: -

- 1.
- 2.
- etc

SIGNED(Applicant)

Dated on.....day of/...20...

FOR OFFICIAL USE ONLY

Lodged with the Secretary Public Procurement Administrative Review Board on day of20.....

SIGNED

Board Secretary

**SECTION VI – SPECIFICATIONS, DRAWINGS AND BILLS OF
QUANTITIES/SCHEDULE OF RATES**

I. SPECIFICATIONS

II. DRAWINGS

III. BILL OF QUANTITIES/SCHEDULE OF RATE

BILL A CONSTRUCTION OF 8.351KM PIPELINE

ITEM NO.	DESCRIPTION	UNIT	QUANTITY	RATE	AMOUNT KSHS
1.0	<u>Clearing of pipeline route</u> Clear pipeline route of bushes, undergrowth, trees, debris and rubbish and dispose. Width of clearance to be 2.0m to accommodate for access road and trench and excavation of materials.	M ²	5,773		
1.1	<u>Excavation</u> Excavate for pipe trench to a depth not exceeding 1000mm for 3” diameter Pvc pipes class C, prepare bed on completion of excavation.	M	7,773		
1.2	Excavate for pipe trench to a depth not exceeding 1000mm for 1” diameter Pvc pipes class C, prepare bed on completion of excavation.	M	578		
	<i>SUB-TOTAL</i>				

ITEM NO.	DESCRIPTION	UNIT	QUANTITY	RATE	AMOUNT KSHS
	<i>Balance Brought Forward</i>				
	<u>Laying and jointing of pvc pipes.</u>				
1.3	Distribute, lay and joint 3” diameter Pvc pipes class D in trench including making provisions for appurtenances and pipe fittings as per specifications.	M	7,773		
1.4	Distribute, lay and joint 1” diameter Pvc pipes class D in trench including making provisions for appurtenances and pipe fittings as per specifications.	M	578		
1.5	<u>Backfilling</u> Backfill trench using well selected excavated material after laying and jointing the 3” and 1” PVC pipes.	M	8,351		
	<i>SUB-TOTAL</i>				

ITEM NO.	DESCRIPTION	UNIT	QUANTITY	RATE	AMOUNT KSHS
	<i>Balance Brought Forward</i>				
1.6	<u>Installation of 7 Consumer WaterMeters</u> Distribute and install No.7 of 15mm Kent Water Meters as directed by the Engineer.	No	7		
1.7	<u>Road crossing</u> Allow for provision of road crossing; GI 150mm pipes to serve as a casing for PVC pipeline	Lump sum	1		
1.8	<u>Construction of valve chambers</u> Construct standard reinforced concrete valve chambers. Include for hardcore fill, boxing out for manhole and fixing of 1No. MS manhole cover and frame light duty 600x 450mm for water master meters, air valves and washout.	No	6		
1.9	<u>Pressure Testing & Disinfection.</u> Allow for carrying out pressure testing on pipeline.	M	7000		
2.0	<u>Installation of Air Valves, Wash out and Water Master Meters.</u> Provide and install 2"water meters at inter connection of the 3" diameter ,rising air valves and wash out to pipeline as instructed on site	No	7		
	<i>SUB-TOTAL</i>				

ITEM NO.	DESCRIPTION	UNIT	QUANTITY	RATE	AMOUNT KSHS
	<i>Balance Brought Forward</i>				
2.1	<u>Construction of interconnection chambers.</u> Supply all materials, construct chambers for interconnection of the gravity main of 3” diameter and the extension distribution mains of 1”	No	2		
2.2	Install and connect to pipeline sluice valve and all other fittings.	No	1		
2.3	<u>Mark post</u> Provide, lay and fix in place and paint pre-cast reinforced concrete marker posts along the pipeline at 200m interval, the posts to be with letter 3” and 1” posts be painted blue. The size to be 75mm x100mm x 150mm long on pipeline.	No	36		
	<i>SUB-TOTAL</i>				Page 48 of 74

ITEM NO.	DESCRIPTION	UNIT	QUANTITY	RATE	AMOUNT KSHS
2.4	<p><i>Balance Brought Forward</i></p> <p><u>Construction of 4 Water yard (Argent)</u></p> <p>Cement</p> <p>Ballast</p> <p>Sand</p> <p>Hardcore</p> <p>Steel meter cover 700mm x 300mm x 3 mm</p> <p>Soft wood timber 8 x 1 x 7"</p> <p>Coral dressed stone 400mm x 200mm x 150mm</p> <p>Brc mesh 2400 x 1200mm</p> <p>Big tap 3/4 "</p> <p>Gate Valve 1"</p> <p>Water Meter 3/4 "</p>	<p>No</p> <p>Ton</p> <p>Ton</p> <p>Ton</p> <p>Pc</p> <p>Pc</p> <p>Pc</p> <p>Pc</p> <p>Pc</p> <p>Pc</p> <p>Pc</p> <p>Pc</p>	<p>24</p> <p>4</p> <p>8</p> <p>4</p> <p>4</p> <p>4</p> <p>160</p> <p>4</p> <p>12</p> <p>8</p> <p>4</p>		

	<i>SUB-TOTAL</i>				
--	-------------------------	--	--	--	--

ITEM NO.	DESCRIPTION	UNIT	QUANTITY	RATE	AMOUNT KSHS
	<i>Balance Brought Forward</i>				
2.5	<u>MATERIALS FOR PIPELINE.</u>				
	PVC 3" Diameter pipes class C	No.	1,296		
	PVC 1" Diameter pipes class C	No.	97		
	PPR ¾" Diameter pipes class D	No.	12		
	GI Tee 3"	No.	4		
	GI Tee 1"	No.	6		
	3" x 1" PVC Reducing Bush	No.	10		
	1" x ¾" PVC Reducing socket	No.	12		
	GI nipple 1"	No.	10		
	¾" Gate valve	No.	16		
	G.I Elbow ¾"	No.	14		
	G.I Bend ¾"	No.	14		
	¾" x ½" G.I Reducing Bush	No.	14		
	Tap (Pegler¾")	No.	11		
	½" Water Meter (Kent)	No.	7		
	GI socket 3"	No.	10		
	PVC Adaptor 3"	No.	10		
	PVC Adaptor 1"	No.	10		
	Solfix cement	LTR.	40		
	<i>SUB-TOTAL</i>				

ITEM NO.	DESCRIPTION	UNIT	QUANTITY	RATE	AMOUNT KSHS
	<i>Balance Brought Forward</i>				
2.6	<u>Materials for valve chambers.</u>				
	Water meter 2" (Kent) Flanged	No.	1		
	Wash out valve 3" Flanged	No.	3		
	Air valve 3" Female screwed	No.	2		
	Gate valve 2" U.K	No.	2		
	G.I Nipple 2"	No.	2		
	G.I 1meter Heavy Duty pipe 3" (one end to be flanged and the other end to be threaded)		6		
	G.I Flanged Heavy Duty 3"	No.	4		
	G.I union 2"	No.	6		
	G.I pipe 2"	No.	6		
	PVC Reducing Socket 3" x 2"	No.	6		
	Bolts, Nuts and Washers of 16mm Diameter of 3" length	No	1000		
	Bolts, Nuts and Washers of 10mm Diameter of 3" length	No	1000		
	G.I 1meter heavy duty pipe 3" screwed both sides	No.	4		
	Cast iron lockable manhole cover	No.	7		
	Solfix cement	LTR.	40		
	Coral Blocks 9" x 9" x 16"	No.	1300		
	Portland Cement	Bag.	80		
	Building Sand	M ³	11		
	Ballast	No.	20		

	SUB-TOTAL				

BILL (B) - FABRICATION & INSTALLATION OF 24M ELEVATED TANK

Item No.	Description	Unit	Qty.	Rate	Amount (Kshs.)
1.0	<u>Excavation and earthworks.</u> Excavate for foundation to a depth not exceeding 3500mm.	Item	1		
1.2	<u>Tank construction.</u> Construct a 50m ³ METRIC COLD Pressed Steel Sectional Water Storage Tank of size 5000mm x 5000mm x 2000mm to BS 1564 Part II complete with 1.5mm thick pitched roof cover, Internal & External ladders, Water Level Indicator, Vent Cleats, Stays, Manhole with lockable cover, Glasticord joining compound, galvanized nuts, bolts & washers. Tank painted with 2 coats Bituprime internally & Aluminium paint externally – Plate thickness 4.5mm.	No.	1		
1.3	Provide 24m high Tank tower to BS 449 complete with walk way, hand rail, ladder painted with 2 coat of Aluminium paint.	No.	1		
1.4	Fabricate and erection of structural steel work for 24m steel tower.	Item	1		
1.5	Allow for piping costs and transportation to site.	Item	1		
1.6	Allow for transport, airtime and supervision cost for Engineers on site(Kshs 100,000)	Ls	1		

	TOTAL				

BILL (C) – CONSTRUCTION OF 50M³ SUMP TANK

Item No.	Description	Unit	Qty.	Rate	Amount (Kshs.)
	<u>Site Clearance</u>				
1.0	Clear tank site of all bushes, scrubs, undergrowth and trees and remove all stumps and roots, dispose as directed by Engineer.	Lump Sum	1		
1.1	Excavate tank site commencing from 200mm below ground level but not exceeding 1.5m deep, dispose excavated material and provide for landscaping.	M ³	60		
1.2	Ditto 1.5m to 3.0m deep.	M ³	20		
1.3	Provide, place and compact 200mm thick hardcore as shown on the drawings.	M ²	40		
1.4	Provide, place 50mm thick blinding 1:3:6 concrete mix on top of hardcore and compact.	M ²	40		
1.5	Provide, mix and place 250mm thick vibrated reinforced concrete 1:2:4 mix to floor slab. Allow for curing.	M ³	10		
1.6	Provide, mix and place 1:3 cement sand screed 20mm thick on top of floor slab. Allow for curing.	M ²	38		
1.7	Provide, place and joint 250mm thick dressed coral stone tank wall in 1:3 cement sand mortar as directed by the engineer.	M ²	37		

1.8	Provide, prepare and apply 1:3 cement sand plaster of 25mm thick to internal sides of tank wall. Allow for water proof cement and curing.	M ²	37		
<i>SUB-TOTAL</i>					

Item No.	Description	Unit	Qty.	Rate	Amount (Kshs.)
	<i>Balance Brought Forward</i>				
1.9	Provide, prepare and apply 1:3 cement sand plaster of 20mm thick to external sides of tank wall. Allow for curing.	M ²	37		
	<u>Reinforcement</u>				
2.0	Provide and fix R8 reinforcement bars in horizontal mortar joint of tank wall as shown on drawing.	M	400		
2.1	Provide and fix Y10 reinforcement bars in concrete foundation of tank bottom as shown on drawings directed by engineer.	M	856		
2.2	Provide and fix Y10 reinforcement bars in concrete roof slab of the tank as shown on the drawing.	M	887		
2.3	Provide a ventilation of 100mm diameter using G.I bends on the roof slab of the tank and fix gauge wire as diameter on site.	No	4		
2.4	Provide and fix all the piping system of inlet, outlet, washout and all other necessary fittings of the tank as directed on site.	Lump sum	1		

2.5	Provide materials and construct 1No. valve chamber at inlet and 1No. Wash out chamber.	No	2		
<i>SUB-TOTAL</i>					

Item No.	Description	Unit	Qty.	Rate	Amount (Kshs.)
	<i>Balance Brought Forward</i>				
	<u>Sundries</u>				
2.6	Provide, mix and place reinforced concrete 1:2:4 to column as shown on the drawings. Allow for plastering. The column size to be 200 x 200mm.	No.	2		
2.7	Provide a manhole opening of size 600mm x 600mm on top of roof with a lockable cover.	No.	1		
2.8	Provide, erect and fix Y10 bar on the floor slab for the columns as shown on the drawings.	M	24		

	TOTAL				

BILL (E) – INSTALLATION OF SOLAR PUMPING SYSTEM

Item No.	Description	Unit	Qty.	Rate	Amount (Kshs.)
	Supply and install a solar pump for pumping water from a 10m deep well to a 24m high 50m ³ water tower. Consider a 54m total head and 50,000 liters daily water requirement.				
1.	LORENTZ PU1800C-SJ5-12 SOLAR PUMP PS4000 4kva	No.	1		
2.	DAYLIFF 330W CRYSTALLINE SOLAR MODULE	No.	6		
3.	LORENTZ PS1800 1.8kva CONTROLLER	No.	1		
4.	DAYLIFF 1 1/2 " ADAPTOR SET	No.	1		
5.	DAYLIFF 1 1/2" STANDARD 3M PIPE	No.	7		
6.	BRAIDED ROPE 12MM	M	25		
7.	WELL-PROBE SENSOR	No.	1		
8.	LONDEX DUAL CORE CABLE	M.	25		
9.	4MM2X4 PVC FLAT SUBMERSIBLE DROP CABLE	M.	25		
10.	MS GROUND MOUNT STRUCTURE/WATT (>20NO.& <195W)	No.	1980		
11.	6MM2X2 SOLAR PV CABLE	M	40		
12.	CABLE JOINT(1.5-4MM) ST6	No.	1		
13.	DAYLIFF SSI1000/16 2ST PV DISCONNECT SWITCH	No.	1		
14.	EARTH ROD C/W CLAMP	No.	1		

15.	COPPER EARTH CABLE 6MM	M.	10		
16.	INSTALLATION SUNDRIES	LS	1		
17.	LABOUR & TRANSPORT CHARGES	LS	1		
TOTAL					

BILL (G) – PROPOSED CONSTRUCTION OF CHAIN LINK FENCE 0.25KM

Item No.	Description	Unit	Qty.	Rate	Amount (Kshs.)
	<u>CHAIN LINK FENCE</u>				
	<u>ALL PROVISIONAL</u>				
A	Clear the site along the perimeter fence of all bushes, shrubs, grass, small trees etc including grabbing up their roots and cart away where necessary.	SM	100		
B	Dig up holes for concrete fencing posts not exceeding 1000mm deep, 400mm diameter @ 3m c/c.	NO	74		
C	Provide and install concrete fencing posts 100mm x 130mm x 3050mm overall length reinforced with 4 Y10 with R6@ 200m c/c with concrete class 20.	NO	74		
D	Ditto but double struts spaced a pair after every 6 days.	NO	24		
E	Provide and fix 12mm diameter fencing nails to fasten the struts to main poles.	NO	24		

F	Fill into strength with mass concrete class 20 to secure fencing posts.	CM	28		
G	Supply and fix barbed wire 12 1/2-gauge x 3 strands galvanized as a fastener to engineer's specification.	Rolls	3		
H	Supply and fix 14-gauge chain link to the engineer's specifications.	SM	528		
I	Supply and fix gauge 10 straining wire	Rolls	4		
<i>SUB-TOTAL</i>					

Item No.	Description	Unit	Qty.	Rate	Amount (Kshs.)
	<i>Balance Brought Forward</i>				
	<u>GATE</u>				
J	Supply and fix steel fabricated gate double leaf 4m wide by 2.4m high lower half covered with gauge 16 plain mild steel sheets and upper half with decorative wire mesh steel patterned in 25 x 25 x 4mm thick RHS including 75 x 50 RHS framing and priming and paint wo.	NO	1		
K	Plain concrete blinding in foundation to column bases	SM	2		
L	Vibrated reinforced concrete 1:2:4 to column bases and columns (columns size 300mm by 300mm)	CM	2		
M	8mm ring to columns @ 200mm c/c	KG	18		
N	10mm diameter reinforcement to column bases and 12mm diameter to columns	KG	28		
O	Formwork	SM	6		
	SUB TOTAL				

GENERAL SUMMARY OF BILL OF QUANTITY FOR JUHUDI MARAFA

BOQ ITEM.	DESCRIPTION	AMOUNT (KSHS)
BILL (A)	CONSTRUCTION OF 8.351KM PIPELINE	
BILL (B)	CONSTRUCTION OF 24M HIGH, 50M³ ELEVATED TANK	
BILL (C)	CONSTRUCTION OF 50M³ SUMP TANK	
BILL (D)	INSTALLATION OF SOLAR PUMPING SYSTEM	
BILL (E)	PROPOSED CONSTRUCTION OF CHAIN LINK FENCE 0.25KM	
	GRAND TOTAL <i>Inclusive of VAT</i>	

NB:

- Pipe line extension from Githurai to Salama and Mkunumbi will serve farmers of Juhudi and Marafa villages. Approximately 5,000 people will be served.
- Source of water LAKWA

PROFILE DRAWINGS FOR JUHUDI MARAFA

LAMU WATER AND SEWERAGE COMPANY LTD

- NOTES
1. Excavated trench shall be equal or greater to 1000mm unless instructed by the site engineer
 2. TBM- temporary bench mark
 3. AV - Air vale
 4. Wo- Wash out
 5. WA - Water arget

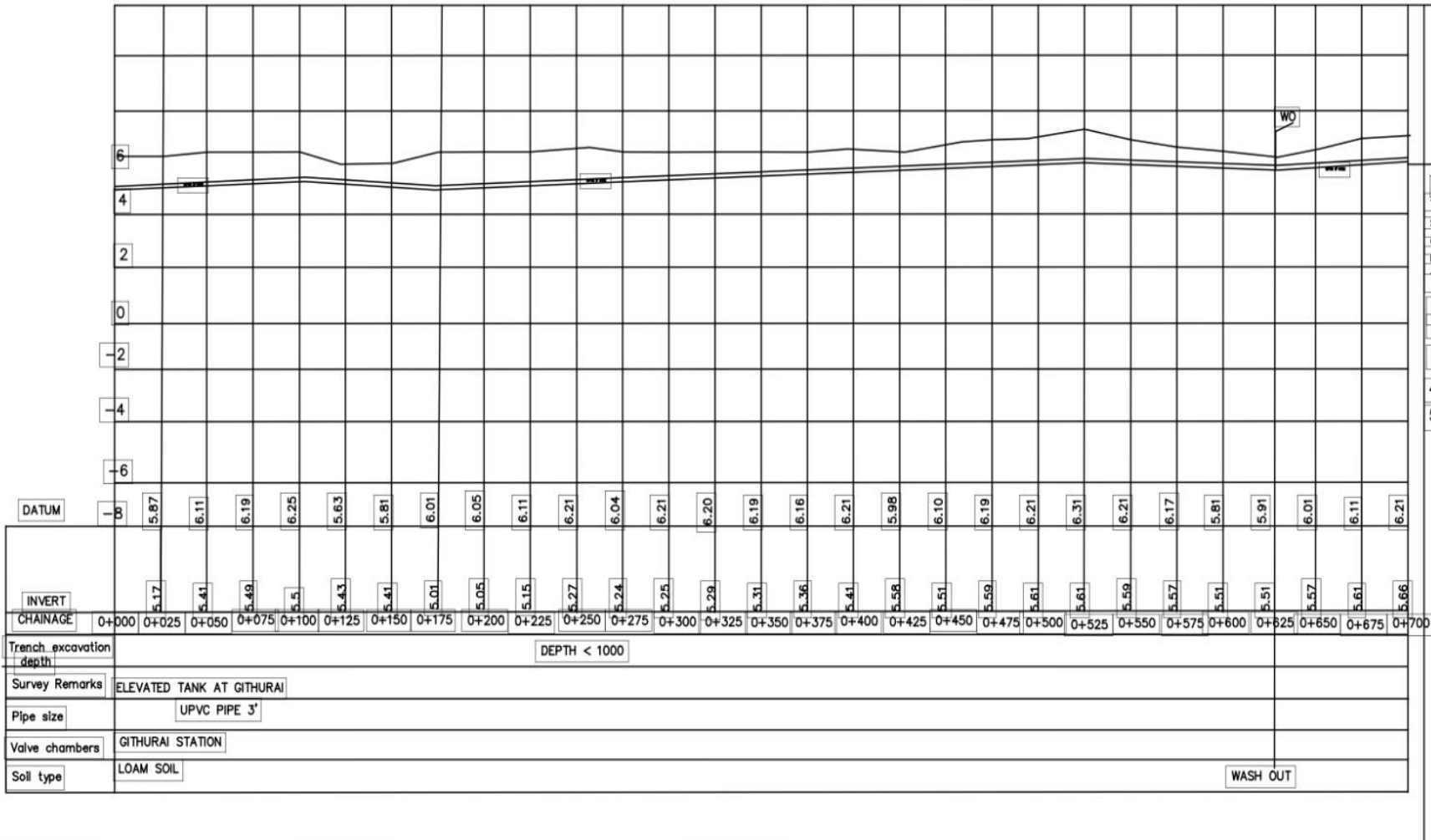

surveyed by CALEB KYAMA DATE 29/5/2020	Drawn by CALEB KYAMA DATE 29/5/2020	Checked by JACOB CHIDZIPHA DATE 2/6/2020	APPROVED BY MANAGING DIRECTOR PK.WAINAINA.....	DATE 2/6/2020	DRAWN SCALE 1:1	SCALE: AS SHOWN	PROJECT: JUHUDI MARAFA SALAMA WATER PIPELINE EXTENSION
--	---	--	--	---------------	-----------------	-----------------	--

LAMU WATER
AND
SEWERAGE
COMPANY LTD

NOTES

- 1. Excavated trench shall be equal to or greater to 1000mm unless instructed otherwise by the site engineer
- 2. TBM – temporary bench mark
- 3. WA – water Ar
- 4. WO – wash ou

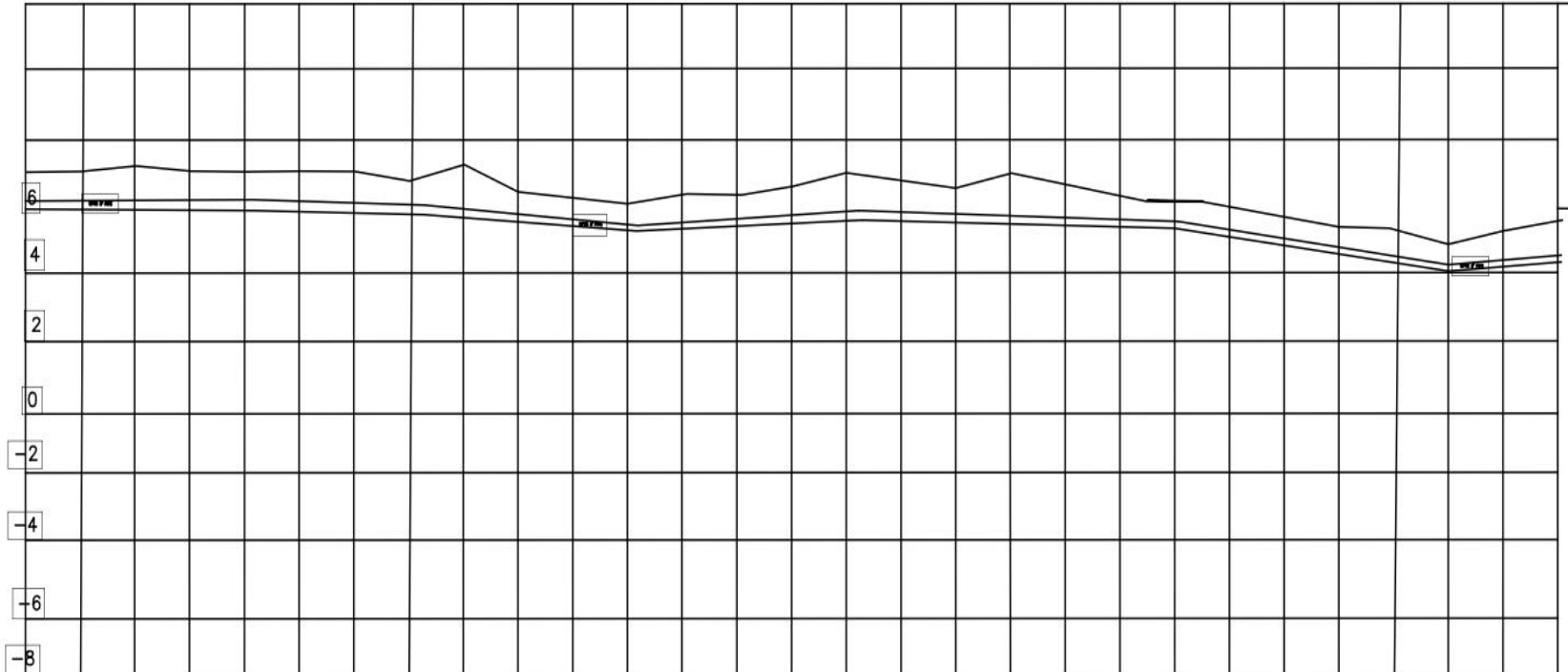

CHAINAGE	0+725	0+750	0+775	0+800	0+825	0+850	0+900	0+925	0+950	0+975	1+000	1+025	1+050	1+075	1+100	1+125	1+150	1+175	1+200	1+225	1+250	1+275	1+300	1+325	1+350	1+375	1+400	1+425	1+450
Trench excavation depth	0<1000mm																												
survey Remarks																													
pipe size	upvc pipe 3"																												
valve chambers																													
Soil type	LOAM SOIL																												

surveyed by Caleb KYAMA DATE 3/10/2019	Drawn by CALEB KYAMA DATE 5/10/2019	Checked by JACOB CHIDZIPHA DATE 8/10/2019	APPROVED MANAGING DIRECTOR PK.WAINAINA	DATE 8/10/2019	DRAWN SCALE 1:1	SCALE: AS SHOWN	PROJECT: POROMOKO WIDHU SALAMA PIPELINE EXTENSION
--	---	---	--	----------------	-----------------	-----------------	--

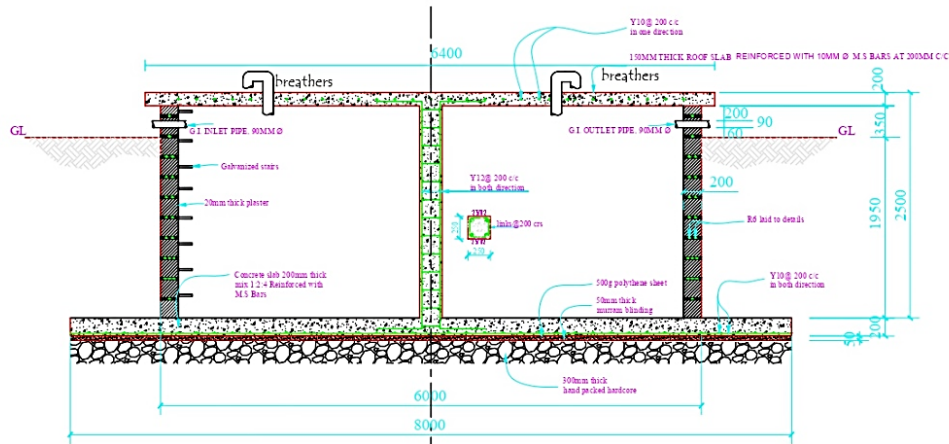

SECTION X-X

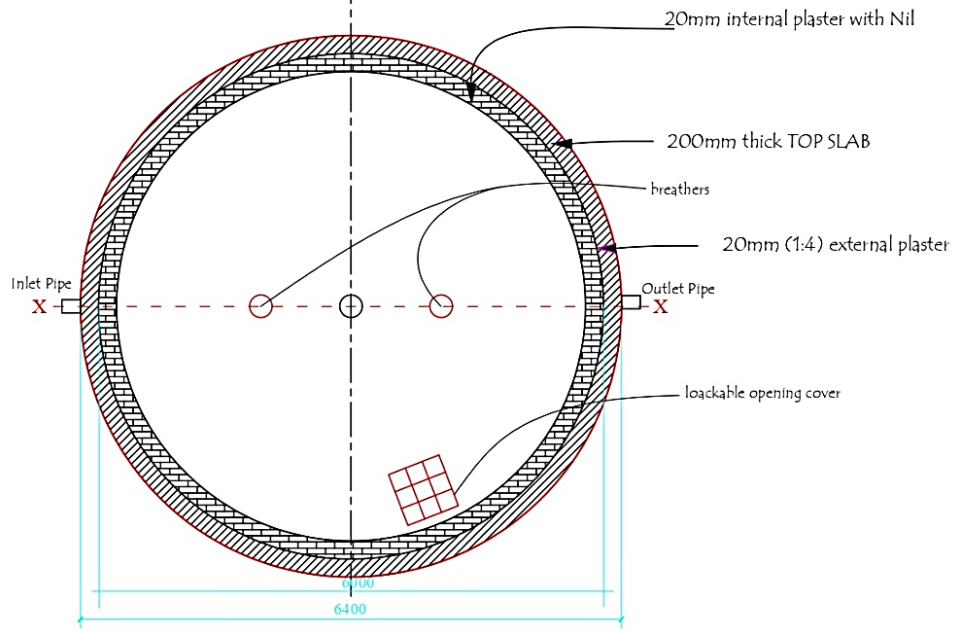

PLAN Scale 1:50

NOTES

1. All measurements in (MM) unless otherwise stated.
2. Reinforced concrete to be 1:2:4 mix by volume.
3. Water cement cover over reinforcement min 40mm.
4. Floor and roof slab to be cast in continuous operations.
5. Surface of the concrete must be kept moist for 8days
6. Shuttering for the roof slab to be adjusted so that at the centre it is 30mm above top level of the tank wall.
7. Supporters to remain in place for 28days after concrete has been cast.
8. No deviation or alteration shall be made from this drawing [PLAN] without client prior consent.
9. Contractor shall read and verify dimensions before starting any work.
10. This drawing should be read in conjunction with structural drawing.
11. Foundation depth to be determined on site.
12. Any discrepancy to be notified to the project consultant at once.

CLIENT:
LAMU WATER & SEWEAGE CO. LTD.

PROJECT:
PROPOSED SOMB SUMP TANK
JUHUDI - NARAFU

Checked by:
Mr. Jacob M. Chidzipha

Reviewed by:
S. Supt. Water, Lamu County: Paul K. Maina

Signed by M.D.
Mr. Wainaina P. K. _____

TITLE: Structural Drawing
Layout Plan
(Sheet 1 of 4)

DATE : AUGUST, 2020 DRG. No.

SCALE: AS SHOWN

DESIGN BY: Eng. SAMUEL M. NIOROGE

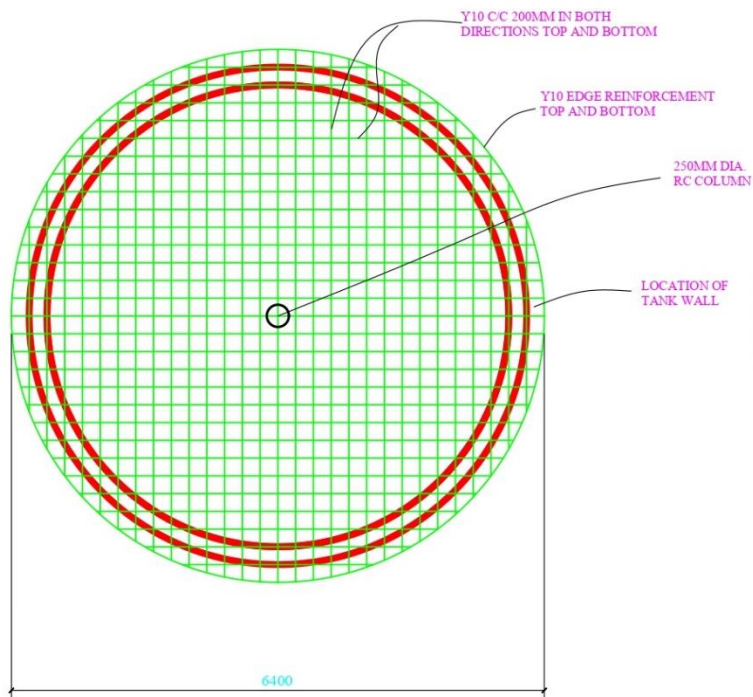

PLAN OF TOP SLAB Scale 1:50

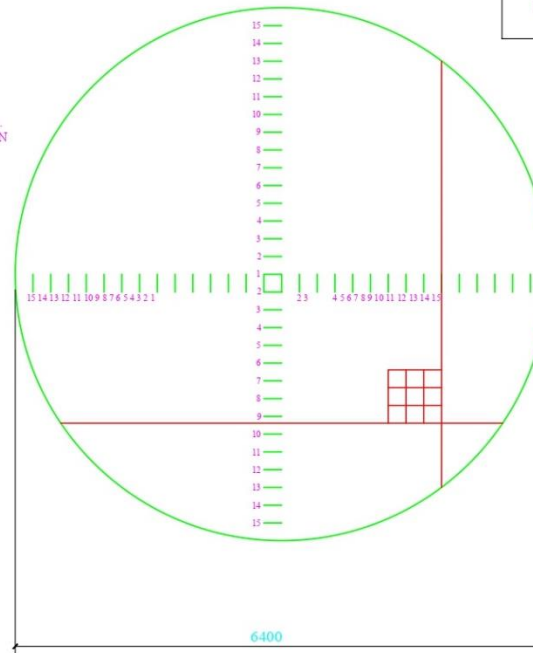

PLAN OF TOP SLAB Scale 1:50

BAR BENDING SCHEDULE

BAR MARK	NO IN EACH	LENGTH OF EACH (mm)	CUT LENGTH (mm)	TOTAL LENGTH (m)	SKETCH OF SHAPE
1	2	6000	6300	12.6	<p>B = 150mm A = L/3 L = Length of bar</p>
2	4	5986.65	6286.65	25.1	
3	4	5946.43	6246.43	25.0	
4	4	5878.78	6178.78	24.7	
5	4	5782.73	6082.73	24.3	
6	4	5656.85	5956.85	23.8	
7	4	5499.09	5799.09	23.2	
8	4	5306.6	5606.6	22.4	
9	4	5075.43	5375.43	21.5	
10	4	4800	5100	20.4	
11	4	4472.14	4772.14	19.1	
12	4	4079.22	4379.22	17.5	
13	4	3600	3900	15.6	
14	4	2993.33	3293.33	13.2	
15	4	2154.07	2454.07	9.8	
				282.0710	

CLIENT:
LAMU WATER & SEWEAGE CO. LTD.

PROJECT:
PROPOSED SOMIS SUMP TANK
JUHUDI-MARAFI

Checked by:
Mr. Jacob M. Chidzipha

Reviewed by:
S. Supt. Water, Lamu County: Paul K. Maina

Signed by M.D.:
Mr. Wainaina P. K. _____

TITLE: Structural Drawing
Layout Plan
(Sheet 2 of 4)

DATE : AUGUST, 2020 DRG. No.
SCALE : AS SHOWN
DESIGN BY: Eng. SAMUEL M. NJOROGE

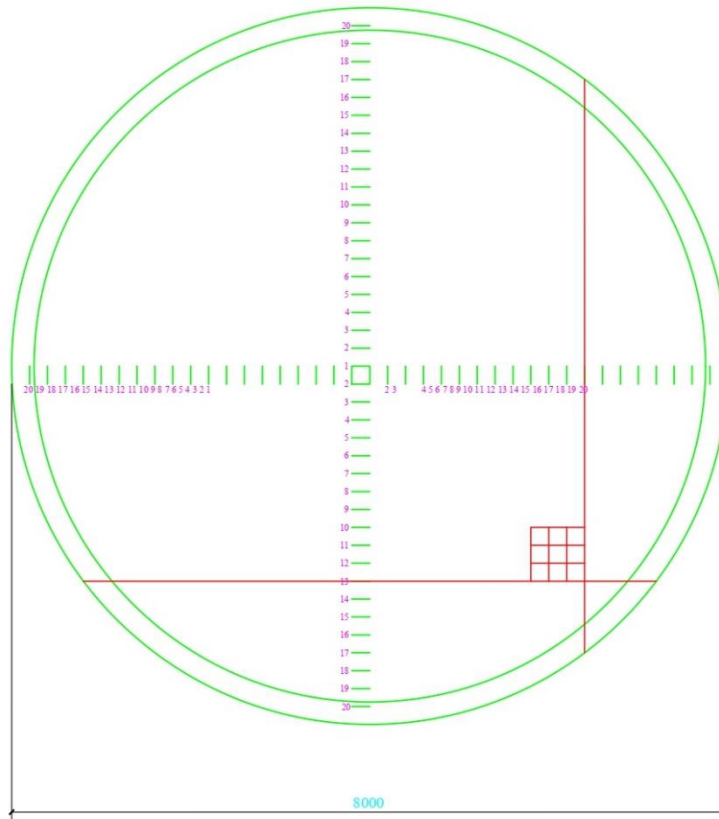

PLAN OF BOTTOM SLAB Scale 1:50

BAR BENDING SCHEDULE

BAR MARK	NO. IN EACH	LENGTH OF EACH (mm)	CUT LENGTH (mm)	TOTAL LENGTH (m)	SKETCH OF SHAPE
1	2	8000	8300	16.6	<p>B=150mm A=L-2B L= Length of bar</p>
2	4	7989.99	8289.99	33.2	
3	4	7959.9	8259.9	33.0	
4	4	7909.49	8209.49	32.8	
5	4	7836.37	8136.37	32.6	
6	4	7745.97	8045.97	32.2	
7	4	7631.51	7931.51	31.7	
8	4	7494	7794	31.2	
9	4	7332.12	7632.12	30.5	
10	4	7144.23	7444.23	29.8	
11	4	6926.2	7226.2	28.9	
12	4	6681.32	6981.32	27.9	
13	4	6400	6700	26.8	
14	4	6079.47	6379.47	25.5	
15	4	5713.14	6013.14	24.1	
16	4	5291.5	5591.5	22.4	
17	4	4800	5100	20.4	
18	4	4214.26	4514.26	18.1	
19	4	3487.12	3787.12	15.1	
20	4	2498	2798	11.2	
				234 (4*5710)	

CLIENT:
LAMU WATER & SEWEARAGE CO. LTD.

PROJECT:
PROPOSED SOMS SUMP TANK
JUHUDI-MARAFI

Checked by:
Mr. Jacob M. Chidzipha

Reviewed by:
S. Supt. Water, Lamu County: Paul K. Maina

Signed by M.D.:
Mr. Wajina P. K. _____

TITLE: Structural Drawing
Layout Plan
(Sheet 3 of 4)

DATE : AUGUST, 2020 DRG. No.
SCALE: AS SHOWN
DESIGN BY: Eng. SAMUEL M. NIOROGE

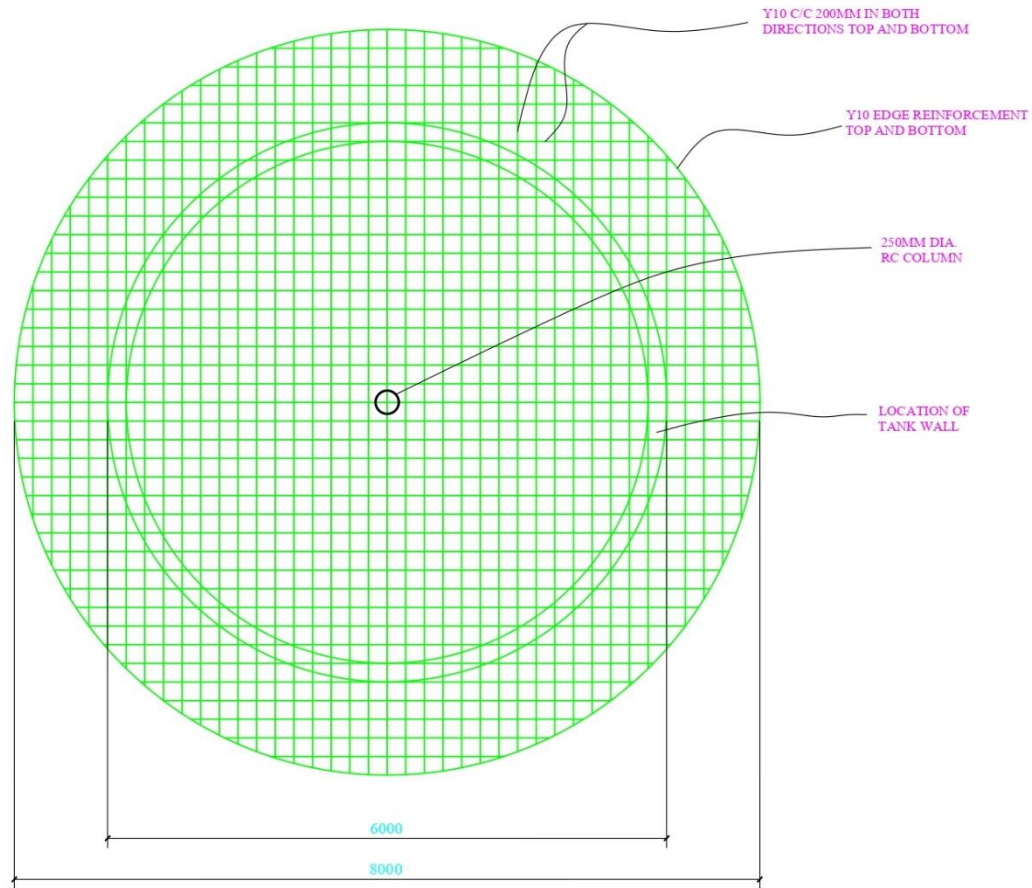

PLAN OF BOTTOM SLAB Scale 1:50

NOTES

1. All measurements in (MM) unless otherwise stated.
2. Reinforced concrete to be 1:2:4 mix by volume.
3. Water cement cover over reinforcement min 40mm.
4. Floor and roof slab to be cast in continuous operations.
5. Surface of the concrete must be kept moist for 8days
6. Shuttering for the roof slab to be adjusted so that at the centre it is 30mm above top level of the tank wall.
7. Supporters to remain in place for 28days after concrete has been cast.
8. No deviation or alteration shall be made from this drawing [PLAN] without client prior consent.
9. Contractor shall read and verify dimensions before starting any work.
10. This drawing should be read in conjunction with structural drawing.
11. Foundation depth to be determined on site.
12. Any discrepancy to be notified to the project consultant at once.

CLIENT:
LAMU WATER & SEWEARAGE CO. LTD.

PROJECT:
PROPOSED SOMS SUMP TANK
JUHUDI-MARAFI

Checked by:
Mr. Jacob M. Chidzapha

Reviewed by:
S. Supt. Water, Lamu County: Paul K. Maina

Signed by M.D.:
Mr. Wajina P. K. _____

TITLE: Structural Drawing
Layout Plan
(Sheet 4 of 4)

DATE : AUGUST, 2020 DRG. No.
SCALE: AS SHOWN
DESIGN BY: Eng. SAMUEL M. NJORGE

NOTES

1. All dimension in mm

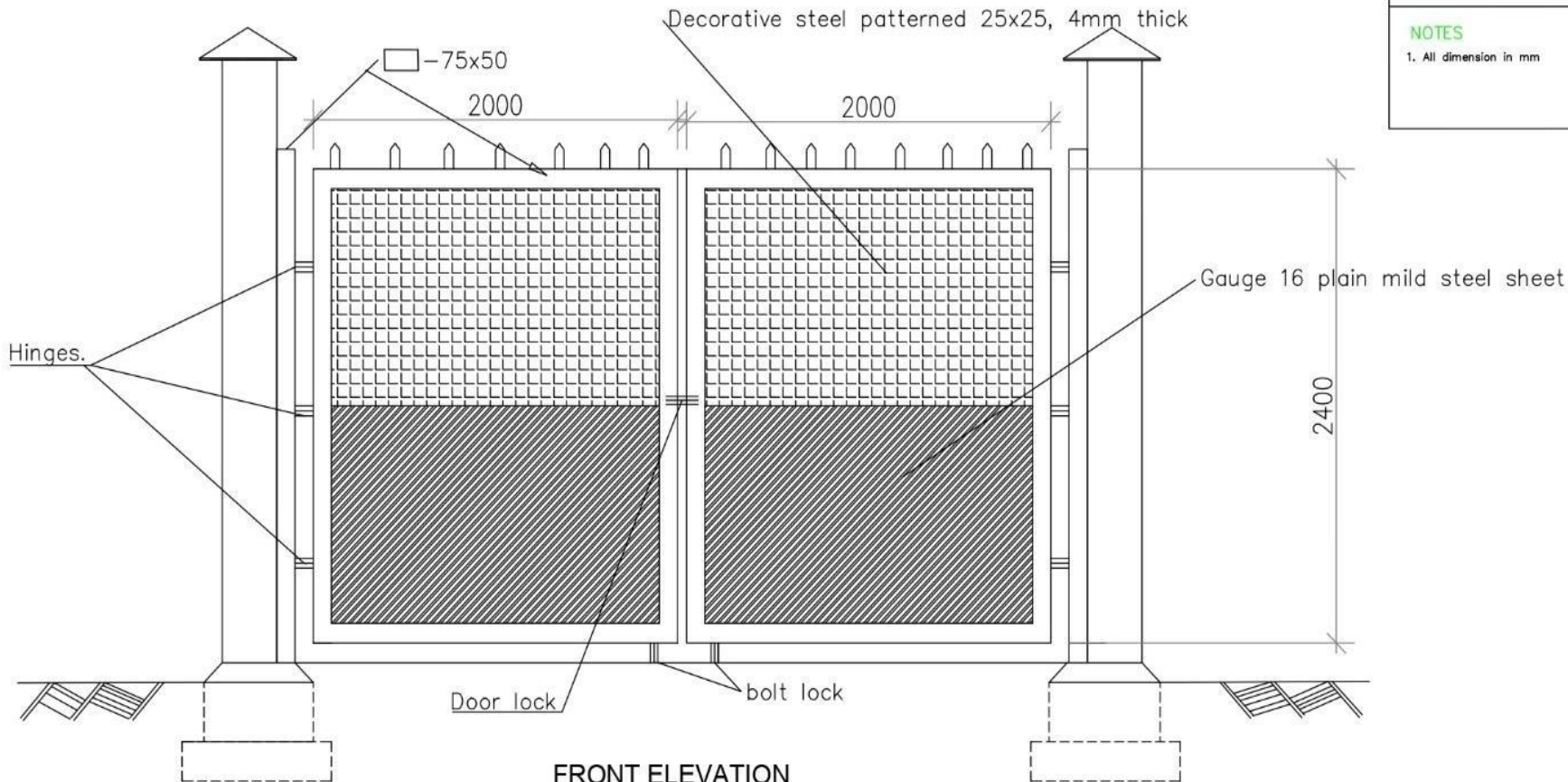

Door lock

bolt lock

Hinges.

-75x50

2000

2000

Decorative steel patterned 25x25, 4mm thick

Gauge 16 plain mild steel sheet

2400

FRONT ELEVATION
Scale 1:100

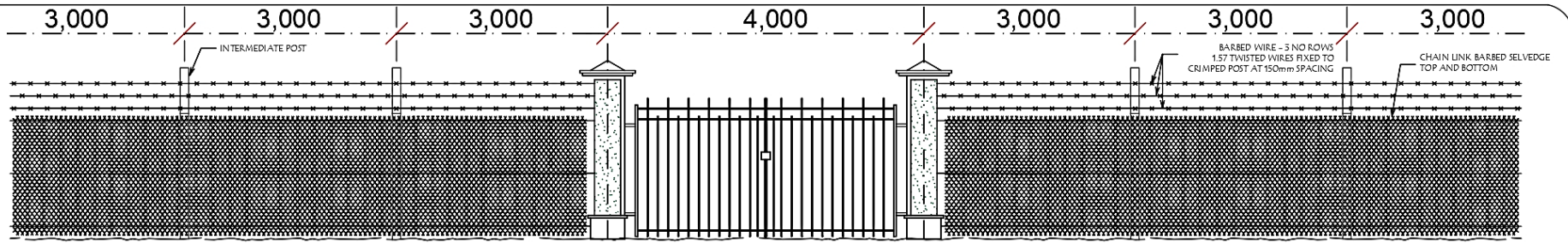

TYPICAL ELEVATION

SCALE 1:100

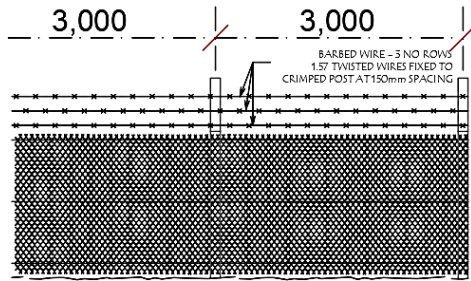

TYPICAL ELEVATION

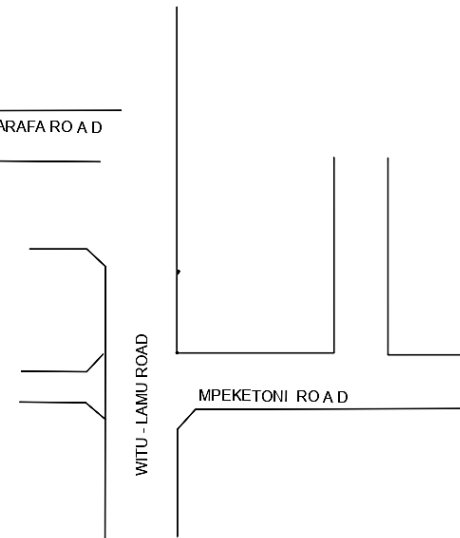
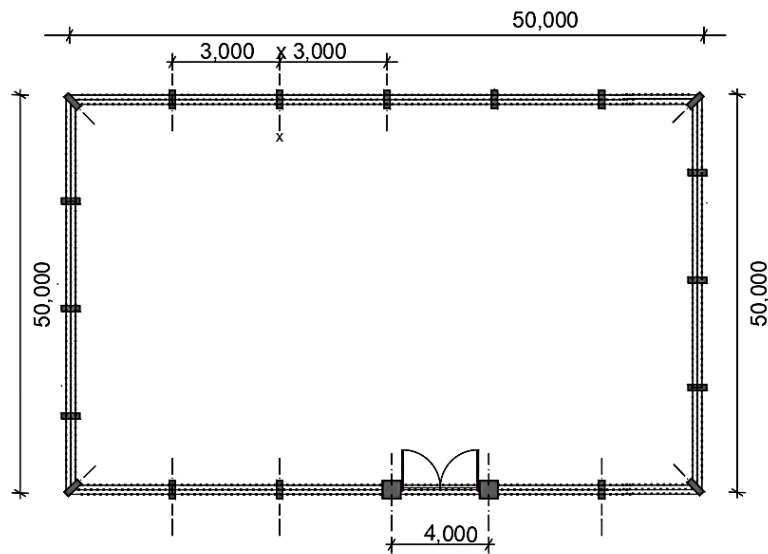
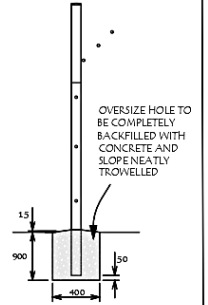
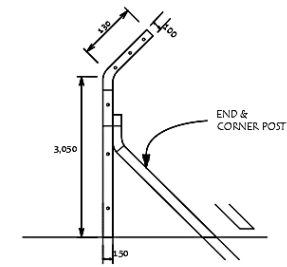
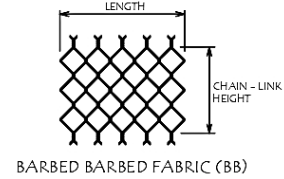
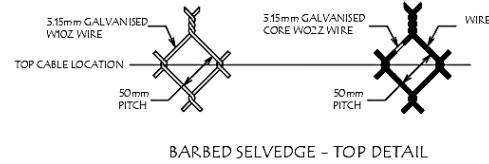

NOTES

- This drawing is to be read in conjunction with bills of quantities, Structural Engineers details, Mechanical Engineers details and Electrical Engineers details.
1. All measurements in (MM) unless otherwise stated.
 2. Only figured dimensions to be read from this drawing in preference to scaled ones.
 3. All walls to be reinforced with hoop iron every alternate course.
 4. All drainage to details and approval of M.O.H
 5. All plumbing works to works to Mechanical Engineers details.
 6. Electrical works to Electrical Engineers details and specifications
 7. All fittings and fitments to detail.

CLIENT: LAMU WATER & SEWEAGE CO. LTD.

PROJECT TITLE: JUHUDI PERIMETER FENCE

Checked by: T.M. Abok M. Chizipha

Signed by M.D. M.D. Wainina P. K.

TITLE: Working Drawing

Plans, Elevations,
Section & Details

DATE: JAN. 2021
DRG. No.
SCALE: AS SHOWN
DESIGN BY: Eng. Samuel M. Njoroge

